



ANTEA NEXT
KC 18-26-30-35
KR 12-24-28-32
KRB 12-24-28-32

IST 03 C 1722 - 01

INSTALLATION AND MAINTENANCE MANUAL



CE

EN

Translation of the original instructions (in Italian)

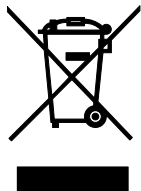

It is compulsory to read this manual before proceeding with the boiler installation, use and maintenance operations.

This boiler is intended for production of hot technical water only:

- For heating of residential, commercial and industrial rooms.
- For heating of industrial process water.
- For indirect production of domestic hot water.

Any other use is forbidden.

General information

Dear Sirs,

thank You for choosing and buying one of our products. Please read these instructions carefully in order to properly install, operate, and maintain the product.

Following the boiler installation, the installer should advise the user about boiler operation and its safety devices.

The USER MANUAL and the INSTALLATION AND MAINTENANCE MANUAL are an integral and essential part of the product. They shall be supplied by the installer to the user who shall keep them carefully to consult them whenever necessary.

These documents shall be supplied together with the equipment in case the latter is sold or transferred to others.



WARNING

We inform users that:

- Boilers shall be installed by an authorised company under the requirements set forth by the prevailing rules, in full compliance with the prevailing regulations and standards.
- Anyone entrusting installation to an unqualified installer will be subject to administrative sanctions.
- Boilers must be maintained by qualified personnel only, under the requirements set forth by the prevailing rules.

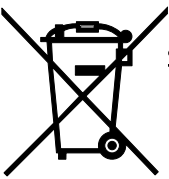

WARNING

According to European Directive 2012/19/EU on waste electrical and electronic equipment (WEEE) the crossed-out wheeled bin symbol indicated on the boiler and on the package means that the boiler, at the time of its decommissioning, must be collected and disposed of separately from other waste (see *Decommissioning, disassembly and disposal*).



WARNING

This boiler is intended for production of hot technical water only:

- For heating of residential, commercial and industrial rooms.
- For heating of industrial process water.
- For indirect production of domestic hot water.

Any other use is forbidden.



DANGER

This boiler must be installed by qualified personnel.
The installation by unqualified personnel is forbidden.



DANGER

This boiler must be installed in compliance with the requirements of the technical standards and legislation in force relating to gas appliances, particularly with reference to ventilation of the premises.

Any installation that does not comply with the requirements of the technical standards and legislation in force is forbidden.



DANGER

This boiler must be installed according to the manufacturer's instructions given in this manual. Incorrect installation may cause injury to persons and/or animals and damage to property. The manufacturer shall not be held liable for any such injury and/or damage.

**WARNING**

This boiler must be installed inside the building or in a partially sheltered place.
A partially sheltered place is a place which is not directly exposed to atmospheric agents.
Any installation in a place that is not partially sheltered is forbidden.

**DANGER**

This boiler must be correctly and safely connected to an electrical system compliant with the existing technical standards.
Any incorrect and unsafe connection to the electrical system is forbidden.
It is forbidden to connect the boiler to an electrical system lacking a differential switch to protect the boiler power line.
Any connection to an electrical system lacking a proper grounding system is forbidden.

**WARNING**

The boiler is supplied with a power cable featuring two poles + GND, already connected to the electronic board and it is provided with a safety clamp.
This boiler must be connected to a 230V power supply network, as indicated on the label.

**DANGER**

Carefully read the instructions relating to air intake and flue gas venting systems in the specific section of this manual.

**DANGER**

This boiler must be connected to a gas distribution system which complies with the existing technical standards.
Check the gas system state of conservation before installing the boiler.
Any connection to a gas system which does not comply with the existing technical standards is forbidden.
When connecting the boiler to gas supply network, it is compulsory to install an appropriately sized gasket made from suitable material.
The boiler gas inlet coupling is not suitable for hemp, teflon tape or similarly made gaskets.
After connecting the boiler, check the connection for tightness.
Once gas is in the pipes, leak test by a naked flame is forbidden; use specific products available on the market.

**DANGER**

With gas fired boilers, take the following measures if you smell gas:

- Do not turn on or off electric switches and do not turn on electric appliances.
- Do not ignite flames and do not smoke.
- Close the main gas cock.
- Open doors and windows.
- Contact a Service Centre, a qualified installer or the gas supply company.

Never use a flame to locate a gas leak.

The boiler is designed for installation in the countries indicated on the technical data plate applied both to the package and to the boiler itself: installation in any other country may be a source of danger for people, animals and/or property.
The manufacturer will bear no contractual and tortious liability for failure to comply with all the instructions above.



WARNING

Before installing the boiler, check that the technical data correspond to the requirements for its correct use in the system. Check that the boiler is intact and it has not been damaged during transport and handling. Do not install equipment which is clearly damaged and/or faulty. The boiler is designed for a fixed installation, the connection to the water system must not be made with removable pipes: for correct installation of the appliance, please refer to section *Hydraulic connections*. Damage and/or injury caused by incorrect installation or use and/or damage and/or injury due to non-observance of the manufacturer's instructions shall release the manufacturer from any and all contractual and extra-contractual liability.

Do not obstruct the air intake openings.

Only original accessories or optional kits (including the electric ones) are to be installed.

Properly dispose of the packaging as all the materials can be recycled. The packaging must therefore be sent to specific waste management sites.

After removing the packaging, make sure that its elements (clips, plastic bags, foam polystyrene etc.) are not left within the reach of children as they are potential hazard sources.

In the event of failure and/or faulty functioning, switch off the boiler. Do not attempt to make repairs: contact qualified technicians.

Original parts must be used for all repairs to the boiler.

Non-observance of the above requirements may affect the safety of the boilers and endanger people, animals and/or property.

The appliance can be used by children aged no less than 8 and by persons with reduced physical, sensory or mental capabilities, or who do not have proper experience and knowledge, provided that they are supervised or they have been instructed on safe use of the appliance and have understood the inherent risks. Do not allow children to play with the appliance. Cleaning and maintenance intended to be carried out by the user shall not be performed by unattended children.



WARNING

An easily accessible switch with contact separation in all poles must be installed upstream of the product, directly connected to the power supply terminals to allow complete disconnection under overvoltage category III conditions and to ensure fully safe maintenance operations.

If the power cable is damaged, it must be replaced by Fondital or its technical service department or a similarly qualified person in order to prevent any risk.



WARNING

The appliance is designed to have a DHW working pressure of 0.6 MPa (6 bar) and a DHW inlet pressure of 0.05 MPa - 0.6 MPa (0.5 bar - 6 bar).



DANGER

Before starting the boiler, and each time it is at a standstill for several days, make sure the trap is full of water.

If the trap is empty, fill it by pouring water into the boiler through the flue gas venting duct.



WARNING

The boiler must be serviced periodically as indicated in the relevant section of this manual.

Appropriate boiler maintenance ensures efficient operation, environment preservation, and safety for people, animals and objects.

Incorrect and irregular maintenance can be a source of danger for people, animals and property.

The user is strongly advised to have the system serviced and repaired by qualified personnel, satisfying all prevailing law requirements, and trained to properly carry out these operations.

In the event of long periods of inactivity of the boiler, disconnect it from the electrical power mains and close the gas cock.



WARNING

With the electrical power disconnected and the gas cock closed, the device's electrical anti-freeze function does not work.

Should there be a risk of freezing, add antifreeze: it is not advisable to drain the system as this may result in damage; use specific anti-freeze products suitable for multi-metal heating systems.



DANGER

Damage and/or injury caused by incorrect installation and/or incorrect use and/or unauthorized changes to the boiler and/or non-observance of the manufacturer's instructions and/or of the relative standards/laws in force in the country of installation, shall release the manufacturer from any and all liability.



The manufacturer declares that this product complies with the essential requirements of the applicable European directives and regulations in force.

The declaration of conformity can be requested from the manufacturer.

We hereby inform you that certain models, versions and/or accessories relevant to the products this manual refers to, might not be available in some countries.

Therefore, it is recommended to contact the manufacturer or the importer in order to get the necessary information about the actual availability of such models, versions and/or accessories.

The manufacturer reserves the right to modify the products and/or its components as deemed necessary, in any moment and without prior notice.

This instruction manual is available in two languages, Italian and English, without prejudice to the prevalence of Italian language in case of differences in translation and/or dispute on construction of the text.

1.	Technical features and dimensions	9
1.1	Technical features	9
1.2	Dimensions	11
1.3	Hydraulic diagrams	14
1.4	Operating data	17
1.5	General characteristics	18
1.6	ERP and Labelling data	21
2.	Instructions for the installer	23
2.1	Installation standards	23
2.2	Choosing where to install the boiler	23
2.3	Positioning the boiler	23
2.4	Minimum installation distances	25
2.5	Installing the boiler	26
2.6	Boiler room ventilation	26
2.7	Air intake and flue gas venting system	27
2.8	Measuring combustion efficiency during operation	42
2.9	Connection to gas mains	43
2.10	Hydraulic connections	43
2.11	Connection to electrical mains	45
2.12	Connection to ambient thermostat (optional)	45
2.13	Ambient probe installation (optional)	45
2.14	Installation and operation with Open Therm Remote Control (optional)	46
2.15	Selecting the operating range in heating mode	47
2.16	Installation of the (optional) external probe and sliding temperature operation	47
2.17	TSP parameters	49
2.18	Filling the system	55
2.19	Starting up the boiler	55
2.20	Available head	56
2.21	Wiring diagrams	59
2.22	Adaptation to other gas types and burner adjustment	66
3.	Testing the boiler	71
3.1	Preliminary checks	71
3.2	Switching on and switching off	71
4.	Maintenance	72
4.1	Maintenance schedule	72
4.2	Combustion analysis	73
4.3	Extraordinary maintenance	73
5.	Decommissioning, disassembly and disposal	74
6.	Malfunctions, possible causes and solutions	75
6.1	Troubleshooting	75

Fig. 1 KC model dimensions	11
Fig. 2 KR model dimensions	12
Fig. 3 KRB model dimensions	13
Fig. 4 KC hydraulic diagram	14
Fig. 5 KR hydraulic diagram	15
Fig. 6 KRB hydraulic diagram	16
Fig. 7 Paper template	24
Fig. 8 Minimum installation distances	25
Fig. 9 Split kit installation	28
Fig. 10 Coaxial kit installation	28
Fig. 11 Installation examples	29
Fig. 12 Pipe installation	29
Fig. 13 Wall-mounted terminal installation	30
Fig. 14 Tile for pitched roofs	30
Fig. 15 Roof flue installation	31
Fig. 16 Split ducts with pipework	39
Fig. 17 Type C13 - C33 coaxial ducts	41
Fig. 18 Coaxial ducts C93	41
Fig. 19 Caps position	42
Fig. 20 Hole position	42
Fig. 21 Connection to gas mains	43
Fig. 22 Condensate drain	44
Fig. 23 Thermoregulation curves	48
Fig. 24 Available head KC 18 - KR/KRB 12	56
Fig. 25 Available head KC 26 - KR/KRB 24	57
Fig. 26 Available head KC 30 - KR/KRB 28	57
Fig. 27 Available head KC 35 - KR/KRB 32	58
Fig. 28 Wiring diagram KC (I)	59
Fig. 29 Wiring diagram KC (II)	60
Fig. 30 Wiring diagram KR (I)	61
Fig. 31 Wiring diagram KR (II)	62
Fig. 32 Wiring diagram KRB (I)	63
Fig. 33 Wiring diagram KRB (II)	64
Fig. 34 Gas diaphragm replacement	66
Fig. 35 Gas valve setting	67
Fig. 36 Offset pressure adjustment	70

Tab. 1 Adjustment specifications KC 18 - KR/KRB 12	17
Tab. 2 Adjustment specifications KC 26 - KR/KRB 24	17
Tab. 3 Adjustment specifications KC 30 - KR/KRB 28	17
Tab. 4 Adjustment specifications KC 35 - KR/KRB 32	17
Tab. 5 KC model general data	18
Tab. 6 KR/KRB model general data	19
Tab. 7 KC 18 - KR/KRB 12 combustion specifications	20
Tab. 8 KC 26 - KR/KRB 24 combustion specifications	20
Tab. 9 KC 30 - KR/KRB 28 combustion specifications	20
Tab. 10 KC 35 - KR/KRB 32 combustion specifications	20
Tab. 11 Additional specifications	20
Tab. 12 ERP and Labelling data - KC	21
Tab. 13 ERP and Labelling data - KR/KRB	22
Tab. 14 Pipe length KC 18 - KR/KRB 12	33
Tab. 15 Pipe length KC 26 - KR/KRB 24	34
Tab. 16 Pipe length KC 30 - KR/KRB 28	35
Tab. 17 Pipe length KC 35 - KR/KRB 32	36
Tab. 18 Flow resistance of separate ducts \varnothing 80 mm	37
Tab. 19 Flow resistance of separate ducts \varnothing 80 + \varnothing 50 mm pipework	37
Tab. 20 Flow resistance of separate ducts \varnothing 80 + \varnothing 60 mm pipework	38
Tab. 21 Calculation of the maximum ducted 60 mm vertical duct	39
Tab. 22 Flow resistance of concentric ducts \varnothing 60/100 mm	40
Tab. 23 Flow resistance of concentric ducts \varnothing 80/125 mm	40
Tab. 24 Burner re-ignition temperature	47
Tab. 25 Limits to be set for TSP parameters and default values in relation to boiler type (TSP0) - I	49
Tab. 26 Limits to be set for TSP parameters and default values in relation to boiler type (TSP0) - II	50
Tab. 27 Limits to be set for TSP parameters and default values in relation to boiler type (TSP0) - III	51
Tab. 28 Limits to be set for TSP parameters and default values in relation to boiler type (TSP0) - IV	52
Tab. 29 Limits to be set for TSP parameters and default values in relation to boiler type (TSP0) - V	53
Tab. 30 Limits to be set for TSP parameters and default values in relation to boiler type (TSP0) - VI	54
Tab. 31 Relationship between "Temperature and Nominal resistance" for temperature probes	65
Tab. 32 Gas diaphragm diameter (mm)	66
Tab. 33 Flue gas CO ₂ rate	68
Tab. 34 Flue gas O ₂ rate	70

1. Technical features and dimensions

1.1 Technical features

This boiler is equipped with a fully pre-mixed gas burner. The following models are available:

- **KC** condensing boiler with sealed chamber and forced draught, supplying CH water and instant DHW production;
- **KR** condensing boiler with sealed chamber and forced draught, supplying CH water only.
- **KRB** condensing boiler with sealed chamber and forced draught, supplying CH water only; with 3-way deviating valve for connection to external water heater (optional).

The following power rates are available:

- **KC 18 - KR/KRB 12:** with heat input of 12.0 kW
- **KC 26 - KR/KRB 24:** with heat input of 23.7 kW
- **KC 30 - KR/KRB 28:** with heat input of 26.7 kW
- **KC 35 - KR/KRB 32:** with heat input of 30.4 kW

All models are equipped with electronic ignition and ionisation flame control device.

The boilers meet local applicable Directives enforced in the country of destination, which are stated on their rating plate.

Installation in any other country may be a source of danger for people, animals and property.

The key technical features of the boilers are listed below.

1.1.1 Manufacturing characteristics

- IPX5D electrically protected control panel.
- Integrated, modulating electronic safety board.
- Electronic start-up with built-in igniter and flame detection.
- Fibre, fully pre-mixed burner.
- Mono-thermal, high efficiency, composite and stainless steel heat exchanger.
- Twin shutter modulating gas valve with constant air/gas ratio.
- Modulating, electronically managed combustion fan.
- High-efficiency CH circulation pump with built-in air purging device.
- Minimum pressure switch.
- Heating flow water temperature probe (double).
- DHW temperature probe (KC).
- Flue gas probe and thermal fuse on primary heat exchanger.
- Integrated, automatic by-pass.
- 9-lt- expansion vessel
- System filler cock.
- System unloading cock. (KC)
- DHW plate heat exchanger made of stainless steel (KC).
- Motorised deviating valve (KC and KRB).
- DHW priority flow switch (KC).
- DHW flow-limiting device - 8 l/min (KC 18), 13 l/min (KC 26), 14 l/min (KC 30) and 16 l/min (KC 35).

1.1.2 User interface

- Colour graphic LCD interface to display and control boiler operating condition: OFF, SUMMER, WINTER.
- CH water temperature regulator: 20-78°C (standard range) or 20-45°C (reduced range).
- DHW water temperature regulator: 35-57°C (KC) - 35-65°C (KR/KRB with optional water heater).
- System water pressure gauge.

1.1.3 Operating features

- CH electronic flame modulation with timer-controlled rising ramp (60 seconds, adjustable).
- DHW electronic flame modulation (KC and KR/KRB models with optional external water heater).
- DHW priority function (KC and KR/KRB models with optional external water heater)
- Flow freeze protection function: ON at 5°C; OFF at 30°C or after 15 minutes of operation if CH temperature > 5 °C.
- DHW freeze protection function (KC): ON at 5°C; OFF at 10°C or after 15 minutes of operation if CH temperature > 5 °C.
- Water heater freeze protection function (for KB/KRB models with optional external water heater equipped with NTC probe): ON at 5 °C; OFF at 10 °C or after 15 of activity if water heater temperature is > 5 °C.
- Timer-controlled flue cleaning function: 15 minutes.
- Anti-legionella function (KR/KRB models with optional external water heater).
- CH Maximum heat input parameter adjustment.
- Ignition heat input adjustment parameter.
- Pre-selection of the heating range: standard or reduced.
- Ignition flame propagation function.
- CH thermostat timer: 240 seconds (adjustable).
- Heating pump post-circulation function, freeze protection and flue cleaning modes: 30 seconds (adjustable).
- DHW post-circulation function (KC and KR/KRB with optional external water heater): 30 seconds.
- Post-circulation function for heating temperature > 78 °C: 30 seconds.
- Post-ventilation function after operation: 10 seconds.
- Post-ventilation function for CH temperature >95 °C.
- Circulation pump and deviating valve anti-seize function: 30 seconds of operation after 24 hours of inactivity.
- Anti-water hammer function: can be set from 0 to 10 seconds through parameter **P15**.
- Ready for connection to an ambient thermostat.
- Ready for operation with an external probe (optional, supplied by the manufacturer).
- Ready for operation with an OpenTherm remote control (optional, supplied by the manufacturer).
- Ready for operation with a module for different temperature zones.
- Ready for integration with solar collectors.

1.2 Dimensions

KC model

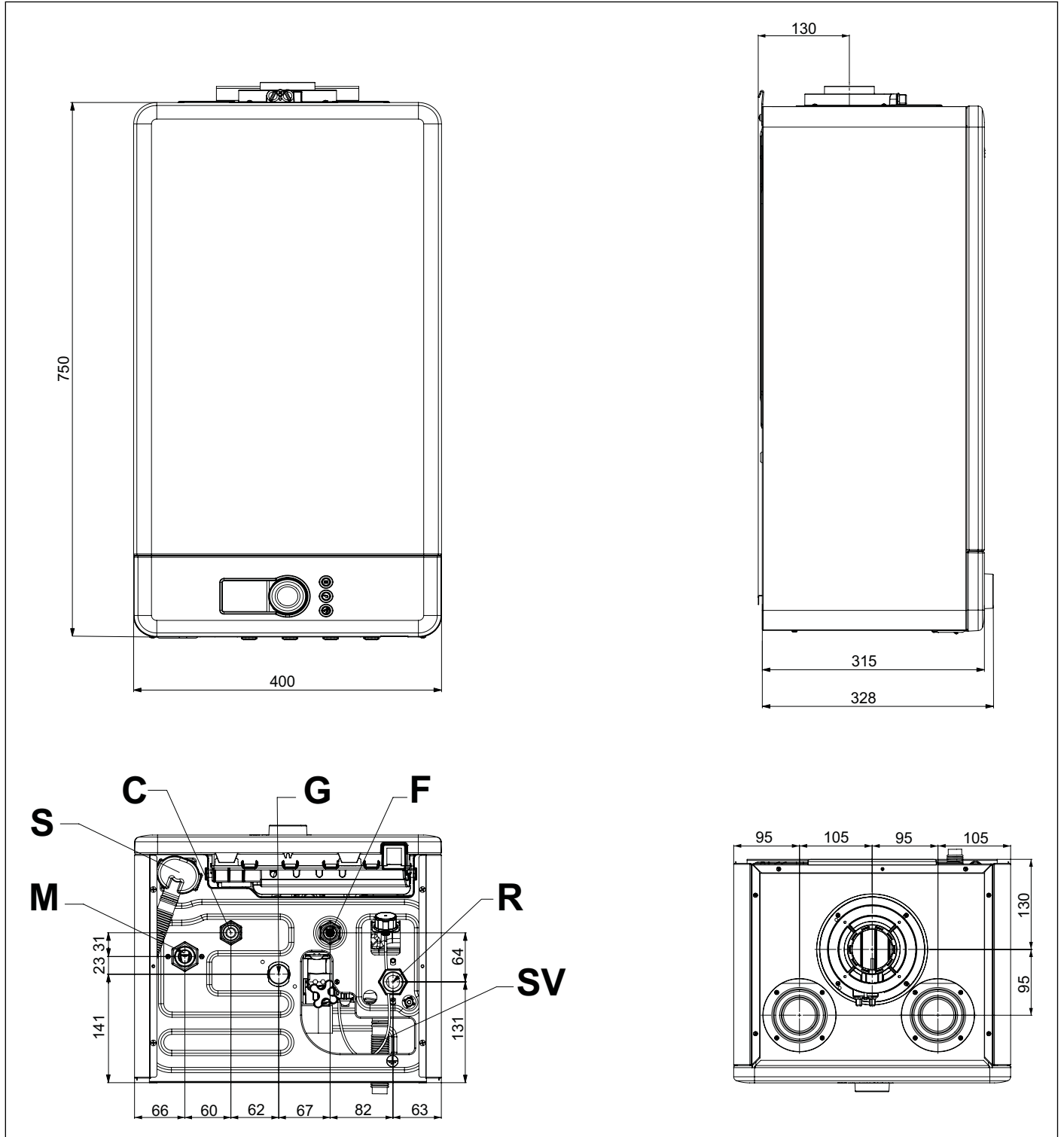

Fig. 1 KC model dimensions

- S Trap
- M CH system flow (3/4")
- C DHW outlet (1/2")
- SV 3-bar safety valve discharge outlet
- G Gas inlet (3/4")
- F Cold water inlet (1/2")
- R CH system return (3/4")

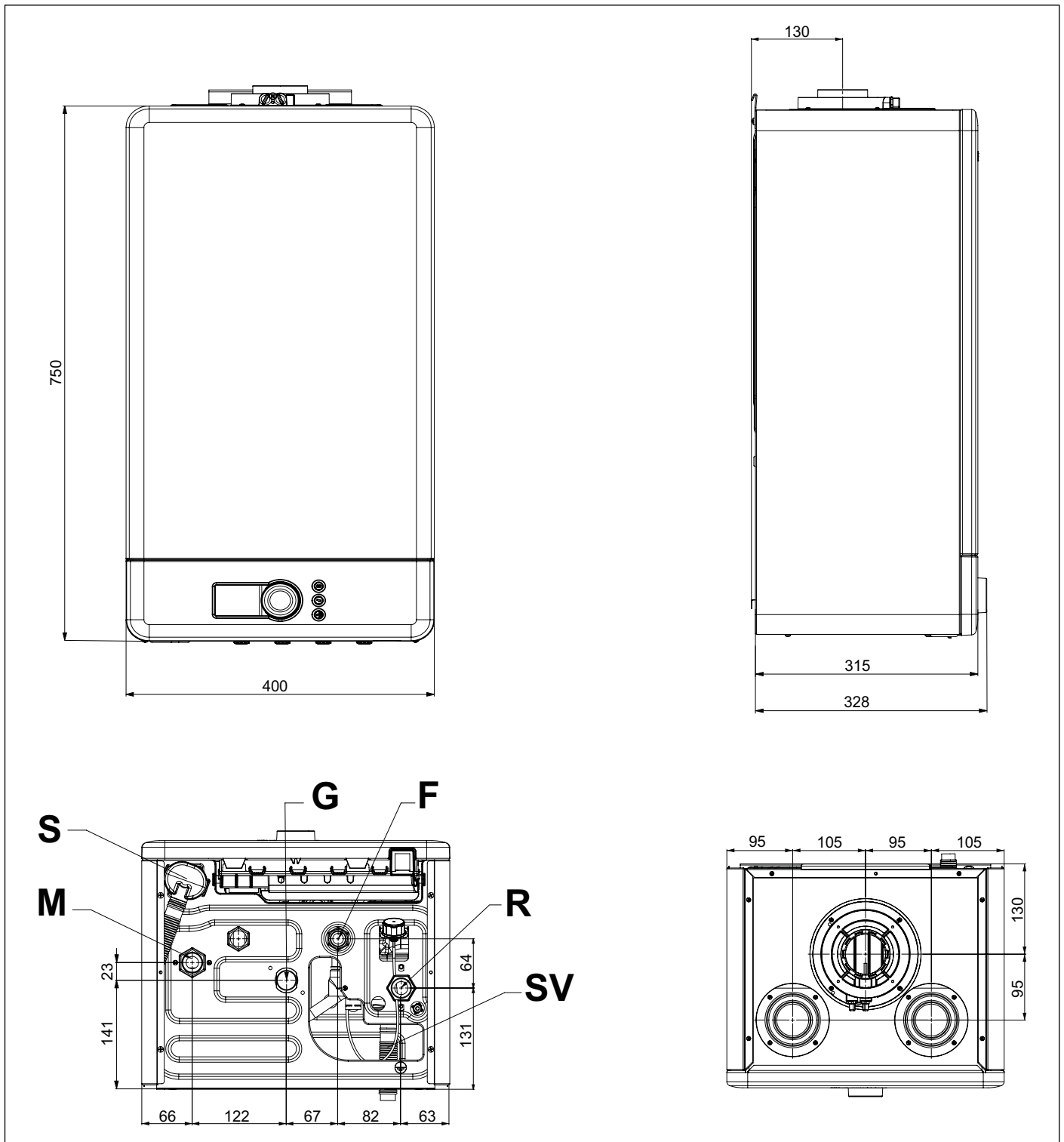

Fig. 2 KR model dimensions

- S Trap
- M CH system flow (3/4")
- SV 3-bar safety valve discharge outlet
- G Gas inlet (3/4")
- F Cold water inlet (1/2")
- R CH system return (3/4")

KRB model

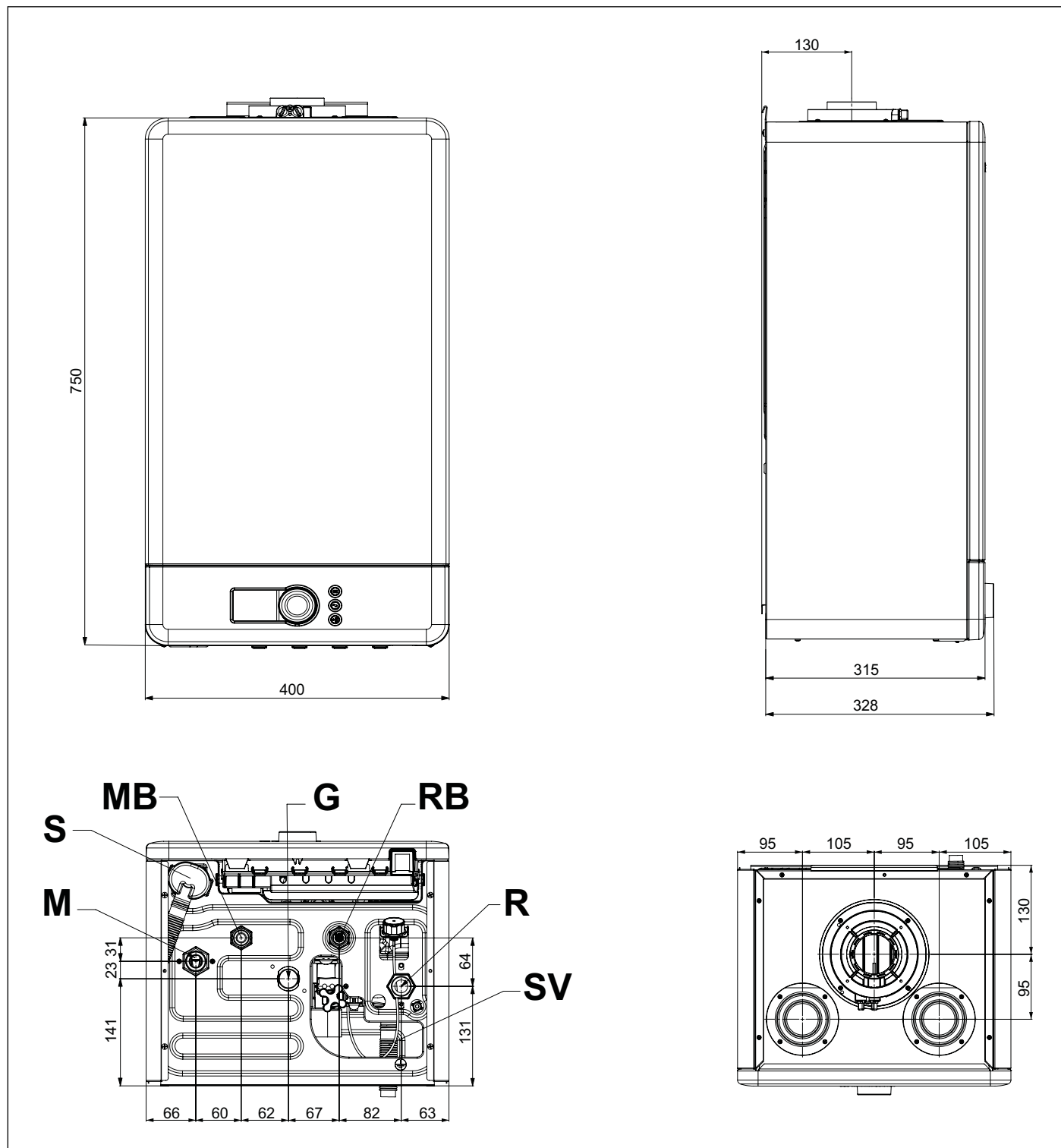

Fig. 3 KRB model dimensions

- S Trap
- M CH system flow (3/4")
- MB Water heater secondary flow (1/2")
- SV 3-bar safety valve discharge outlet
- G Gas inlet (3/4")
- RB Water heater secondary return (1/2")
- R CH system return (3/4")

1.3 Hydraulic diagrams

KC model

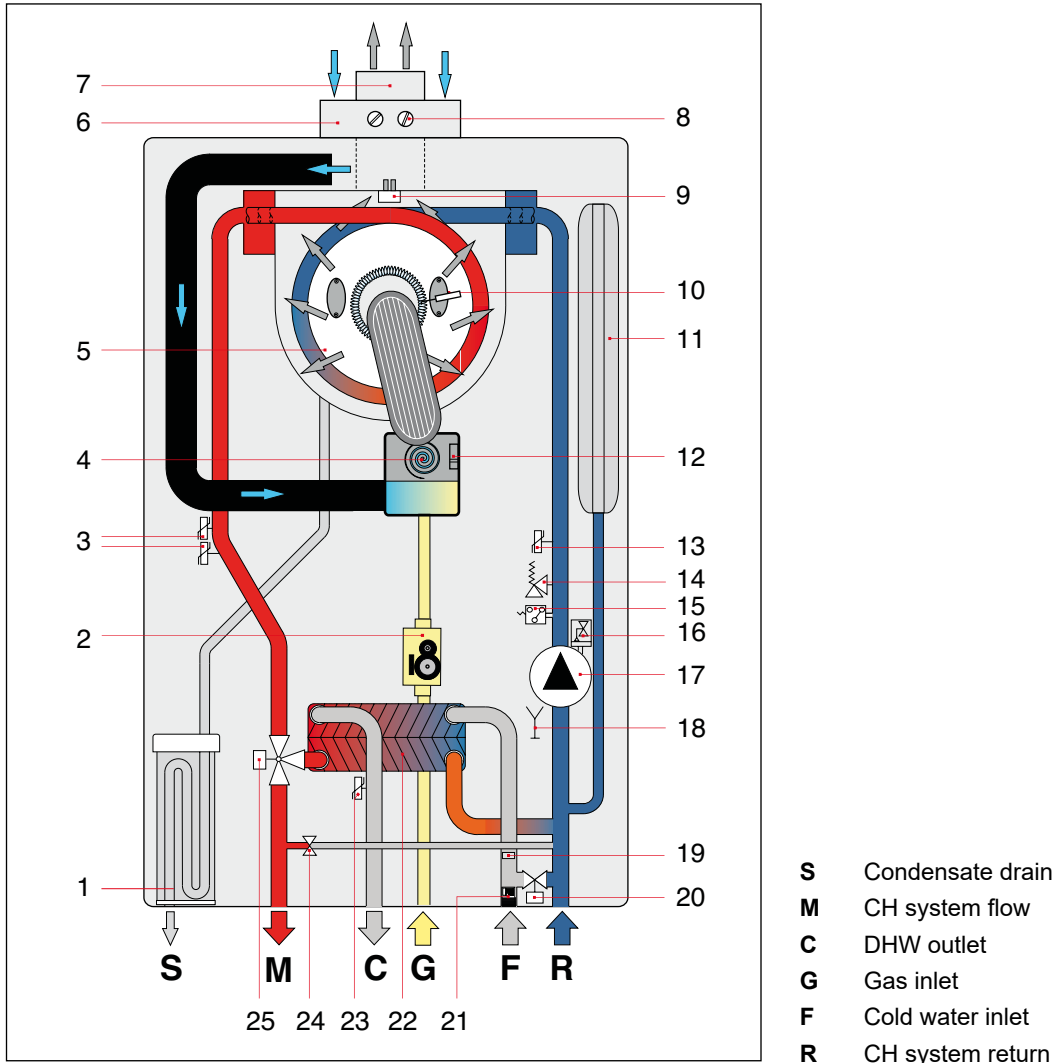
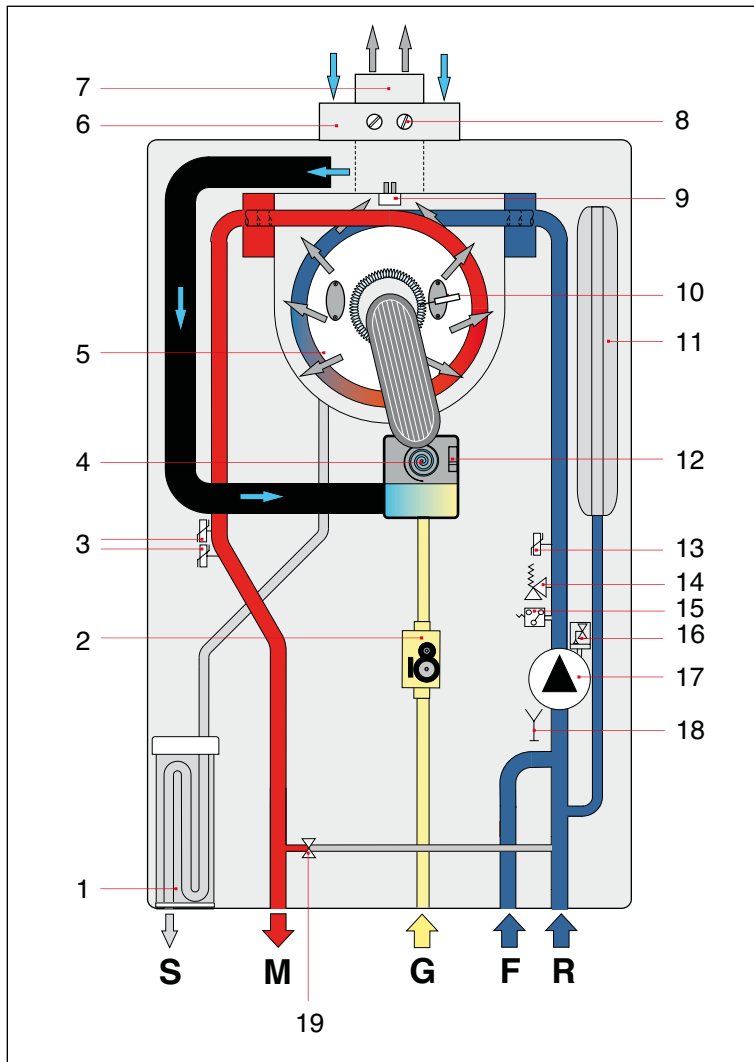

Fig. 4 KC hydraulic diagram

- | | |
|----------------------------------|--|
| 1. Condensate trap | 14. 3-bar safety valve |
| 2. Modulating gas valve | 15. Minimum pressure switch |
| 3. Flow temperature twin probe | 16. Air-purging device |
| 4. Modulating fan | 17. Circulation pump |
| 5. Primary condensing exchanger | 18. System discharge cock. |
| 6. Air intake duct | 19. DHW flow rate limiting device |
| 7. Flue gas venting duct | 20. Filler cock |
| 8. Flue gas analysis ports | 21. Cold water flow switch with filter |
| 9. Flue probe and thermal fuse | 22. Secondary plate exchanger |
| 10. Ignition/detection electrode | 23. DHW temperature probe |
| 11. Expansion vessel | 24. Automatic by-pass |
| 12. Fan check probe | 25. Motorised 3-way valve |
| 13. Return temperature probe | |

KR model



- S** Condensate drain
- M** CH system flow
- G** Gas inlet
- F** Cold water inlet
- R** CH system return

Fig. 5 KR hydraulic diagram

- 1. Condensate trap
- 2. Modulating gas valve
- 3. Flow temperature twin probe
- 4. Modulating fan
- 5. Primary condensing exchanger
- 6. Air intake duct
- 7. Flue gas venting duct
- 8. Flue gas analysis ports
- 9. Flue probe and thermal fuse
- 10. Ignition/detection electrode
- 11. Expansion vessel
- 12. Fan check probe
- 13. Return temperature probe
- 14. 3-bar safety valve
- 15. Minimum pressure switch
- 16. Air-purging device
- 17. Circulation pump
- 18. System discharge cock.
- 19. Automatic by-pass

KRB model

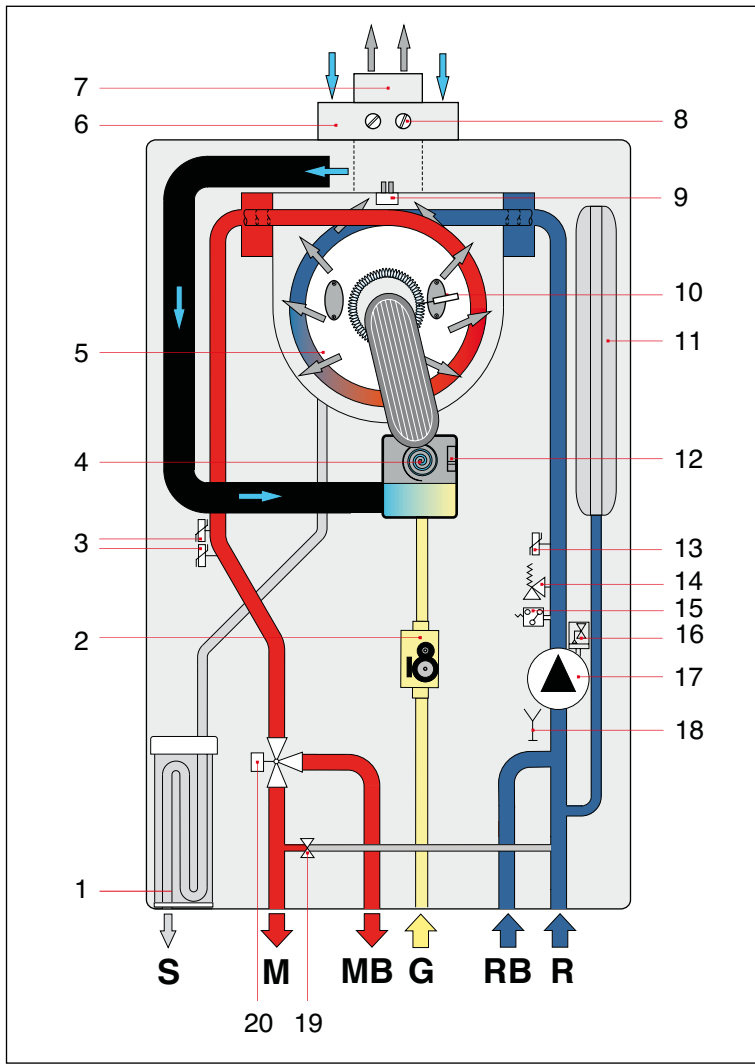

- S** Condensate drain
- M** CH system flow
- MB** Water heater flow
- G** Gas inlet
- RB** Return from the water heater
- R** CH system return

Fig. 6 KRB hydraulic diagram

- | | |
|---|--|
| <ul style="list-style-type: none"> 1. Condensate trap 2. Modulating gas valve 3. Flow temperature twin probe 4. Modulating fan 5. Primary condensing exchanger 6. Air intake duct 7. Flue gas venting duct 8. Flue gas analysis ports 9. Flue probe and thermal fuse 10. Ignition/detection electrode | <ul style="list-style-type: none"> 11. Expansion vessel 12. Fan check probe 13. Return temperature probe 14. 3-bar safety valve 15. Minimum pressure switch 16. Air-purging device 17. Circulation pump 18. System discharge cock. 19. Automatic by-pass 20. Motorised 3-way valve |
|---|--|

1.4 Operating data

Burner pressures reported in the following page must be verified after the boiler has been operating for 3 minutes.

Gas category: II2H3P



WARNING

The boiler is suitable for the use of group H and/or group E fuel gases and mixtures of natural gas and hydrogen up to 20% by volume.

Fuel	Supply pressure [mbar]	Diaphragm diameter [mm]	Flue CO ₂ value Qmax ⁽¹⁾ [%]	Flue CO ₂ value Qmin [%]	O ₂ value Qmax ⁽¹⁾ [%]	O ₂ value Qmin [%]	Offset value [Pa]
Natural gas G20 (*)	20	4,0	9,30 ± 0,45	9,00 ± 0,45	4,40 ± 0,80	4,90 ± 0,80	-10 -5/+3
Propane Gas G31	37	3,1	10,20 ± 0,45	9,00 ± 0,45	5,40 ± 0,80	7,30 ± 0,80	-7 -5/+3

Tab. 1 Adjustment specifications KC 18 - KR/KRB 12

Fuel	Supply pressure [mbar]	Diaphragm diameter [mm]	Flue CO ₂ value Qmax ⁽¹⁾ [%]	Flue CO ₂ value Qmin [%]	O ₂ value Qmax ⁽¹⁾ [%]	O ₂ value Qmin [%]	Offset value [Pa]
Natural gas G20 (*)	20	4,8	9,30 ± 0,45	8,10 ± 0,45	4,40 ± 0,80	6,50 ± 0,80	-10,4 -5/+3
Propane Gas G31	37	3,9	10,60 ± 0,45	9,20 ± 0,45	4,90 ± 0,80	6,90 ± 0,80	-5,8 -5/+3

Tab. 2 Adjustment specifications KC 26 - KR/KRB 24

Fuel	Supply pressure [mbar]	Diaphragm diameter [mm]	Flue CO ₂ value Qmax ⁽¹⁾ [%]	Flue CO ₂ value Qmin [%]	O ₂ value Qmax ⁽¹⁾ [%]	O ₂ value Qmin [%]	Offset value [Pa]
Natural gas G20 (*)	20	5,1	9,30 ± 0,45	8,10 ± 0,45	4,40 ± 0,80	6,50 ± 0,80	-9,5 -5/+3
Propane Gas G31	37	4,1	10,60 ± 0,45	9,20 ± 0,45	4,90 ± 0,80	6,90 ± 0,80	-6,6 -5/+3

Tab. 3 Adjustment specifications KC 30 - KR/KRB 28

Fuel	Supply pressure [mbar]	Diaphragm diameter [mm]	Flue CO ₂ value Qmax ⁽¹⁾ [%]	Flue CO ₂ value Qmin [%]	O ₂ value Qmax ⁽¹⁾ [%]	O ₂ value Qmin [%]	Offset value [Pa]
Natural gas G20 (*)	20	5,5	9,30 ± 0,45	8,30 ± 0,45	4,40 ± 0,80	6,10 ± 0,80	-9,4 -5/+3
Propane Gas G31	37	4,4	10,60 ± 0,45	9,20 ± 0,45	4,80 ± 0,80	7,00 ± 0,80	-8,4 -5/+3

Tab. 4 Adjustment specifications KC 35 - KR/KRB 32

(1) DHW maximum heat input

(*) When using mixtures containing up to 20% hydrogen (H₂) for calibration please refer to section *Mains gas valve setting 20%H2NG* on page 69

1.5 General characteristics

Description	um	KC 18	KC 26	KC 30	KC 35
CH nominal heat input	kW	12,0	23,7	26,7	30,4
Minimum heat input	kW	2,0	3,0	3,3	4,2
CH nominal heat input with mixture 20%H2NG ($Q_{n(20\%H_2)}$)	kW	11,4	22,4	25,3	28,8
CH minimum heat input with mixture 20%H2NG	kW	1,9	2,8	3,1	4,0
Maximum heat output (80-60°C) - CH	kW	11,8	23,1	26,0	29,6
Minimum heat output (80-60°C) - CH	kW	1,8	2,8	3,1	3,8
Maximum heat output (50-30°C) - CH	kW	12,9	25,0	28,1	32,2
Minimum heat output (50-30°C) - CH	kW	2,1	3,3	3,4	4,4
Minimum CH system pressure	bar	0,5	0,5	0,5	0,5
Maximum CH system pressure	bar	3,0	3,0	3,0	3,0
DHW maximum heat input	kW	18,0	27,3	30,4	34,5
DHW minimum heat input	kW	2,0	3,0	3,3	4,2
DHW nominal heat input with mixture 20%H2NG ($Q_{nw(20\%H_2)}$)	kW	17,0	25,9	28,8	32,7
DHW nominal heat input with mixture 20%H2NG	kW	1,9	2,8	3,1	4,0
DHW circuit min. pressure	bar	0,5	0,5	0,5	0,5
DHW circuit max. pressure	bar	6,0	6,0	6,0	6,0
DHW specific flow rate ($\Delta t=30K$)	l/min	9,0	13,4	15,0	17,3
Electric power supply – voltage / frequency	V - Hz	230 -50	230 -50	230 -50	230 -50
Power mains supply fuse	A	3,15	3,15	3,15	3,15
Maximum power consumption	W	96	106	111	122
Pump absorption	W	46	46	46	54
Electric protection rating	IP	X5D	X5D	X5D	X5D
Net weight	kg	29,0	29,0	31,0	31,5
Natural gas consumption at maximum CH output (Value referred to 15 °C - 1013 mbar)	cu. m/h	1,27	2,51	2,82	3,22
Propane gas consumption at maximum CH output	kg/h	0,93	1,84	2,07	2,36
Maximum CH working temperature	°C	83	83	83	83
Maximum DHW working temperature	°C	62	62	62	62
Total capacity of expansion vessel	l	9	9	9	9
Maximum recommended system capacity (Maximum water temperature 83°C, expansion vessel pressure 1 bar)	l	200	200	200	200

Tab. 5 KC model general data

Description	um	KR 12 KRB 12	KR 24 KRB 24	KR 28 KRB 28	KR 32 KRB 32
CH nominal heat input	kW	12,0	23,7	26,7	30,4
Minimum heat input	kW	2,0	3,0	3,3	4,2
CH nominal heat input with mixture 20%H2NG ($Q_{n(20\%H_2)}$)	kW	11,4	22,4	25,3	28,8
CH minimum heat input with mixture 20%H2NG	kW	1,9	2,8	3,1	4,0
Maximum heat output (80-60°C) - CH	kW	11,8	23,1	26,0	29,6
Minimum heat output (80-60°C) - CH	kW	1,8	2,8	3,1	3,8
Maximum heat output (50-30°C) - CH	kW	12,9	25,0	28,1	32,2
Minimum heat output (50-30°C) - CH	kW	2,1	3,3	3,4	4,4
Minimum CH system pressure	bar	0,5	0,5	0,5	0,5
Maximum CH system pressure	bar	3,0	3,0	3,0	3,0
DHW maximum heat input (*)	kW	18,0	27,3	30,4	34,5
DHW minimum heat input (*)	kW	2,0	3,0	3,3	4,2
DHW nominal heat input with mixture 20%H2NG ($Q_{nw(20\%H_2)}$) (*)	kW	17,0	25,9	28,8	32,7
DHW nominal heat input with mixture 20%H2NG (*)	kW	1,9	2,8	3,1	4,0
Electric power supply – voltage / frequency	V - Hz	230 -50	230 -50	230 -50	230 -50
Power mains supply fuse	A	3,15	3,15	3,15	3,15
Maximum power consumption	W	96	106	111	122
Pump absorption	W	46	46	46	54
Electric protection rating	IP	X5D	X5D	X5D	X5D
Net weight	kg	28,0	28,0	30,0	30,5
Natural gas consumption at maximum CH output (Value referred to 15 °C - 1013 mbar)	cu. m/h	1,27	2,51	2,82	3,22
Propane gas consumption at maximum CH output	kg/h	0,93	1,84	2,07	2,36
Maximum CH working temperature	°C	83	83	83	83
Maximum DHW working temperature (**)	°C	65	65	65	65
Total capacity of expansion vessel	l	9	9	9	9
Maximum recommended system capacity (Maximum water temperature 83°C, expansion vessel pressure 1 bar)	l	200	200	200	200

Tab. 6 KR/KRB model general data

(*) KR/KRB models with optional external water heater.

(**) KR/KRB models with water heater probe, optional.

Description	um	Max. output	Min. output	30% load
Casing heat loss with burner on	%	0,00	6,75	-
Casing heat loss with burner off	%		0,42	
Flue system heat loss with burner on	%	1,99	8,62	-
Flue system mass capacity	g/s	8,0	0,9	-
Flue temp. – air temp.	°C	47	47	-
Heat output efficiency rating (80-60°C)	%	98,0	91,4	-
Heat output efficiency rating (50-30°C)	%	107,5	103,3	-
Heat output efficiency rating with 30% of the load	%	-	-	108,3
NOx emission class	-		6	

Tab. 7 KC 18 - KR/KRB 12 combustion specifications

Description	um	Max. output	Min. output	30% load
Casing heat loss with burner on	%	0,33	2,95	-
Casing heat loss with burner off	%		0,21	
Flue system heat loss with burner on	%	2,66	5,08	-
Flue system mass capacity	g/s	12,2	1,5	-
Flue temp. – air temp.	°C	54	51	-
Heat output efficiency rating (80-60°C)	%	97,3	94,9	-
Heat output efficiency rating (50-30°C)	%	105,5	109,0	-
Heat output efficiency rating with 30% of the load	%	-	-	108,4
NOx emission class	-		6	

Tab. 8 KC 26 - KR/KRB 24 combustion specifications

Description	um	Max. output	Min. output	30% load
Casing heat loss with burner on	%	0,55	4,27	-
Casing heat loss with burner off	%		0,23	
Flue system heat loss with burner on	%	2,66	6,21	-
Flue system mass capacity	g/s	13,5	1,7	-
Flue temp. – air temp.	°C	55	51	-
Heat output efficiency rating (80-60°C)	%	97,3	93,8	-
Heat output efficiency rating (50-30°C)	%	105,4	103,2	-
Heat output efficiency rating with 30% of the load	%	-	-	108,0
NOx emission class	-		6	

Tab. 9 KC 30 - KR/KRB 28 combustion specifications

Description	um	Max. output	Min. output	30% load
Casing heat loss with burner on	%	0,43	6,29	-
Casing heat loss with burner off	%		0,21	
Flue system heat loss with burner on	%	2,74	8,47	-
Flue system mass capacity	g/s	15,4	2,1	-
Flue temp. – air temp.	°C	55	52	-
Heat output efficiency rating (80-60°C)	%	97,3	91,5	-
Heat output efficiency rating (50-30°C)	%	105,9	103,8	-
Heat output efficiency rating with 30% of the load	%	-	-	107,8
NOx emission class	-		6	

Tab. 10 KC 35 - KR/KRB 32 combustion specifications

Additional specifications (EN 15502-1)	um	Value
Maximum operating temperature of the combustion products	°C	120
Overheating temperature of the combustion products	°C	120
Installation type: C63 - Maximum air temperature on intake	°C	40
Installation type: C63 - Maximum flue gas recirculation at the terminal	%	10

Tab. 11 Additional specifications

1.6 ERP and Labelling data

Model(s): ANTEA NEXT			KC 18	KC 26	KC 30	KC 35
Condensing boiler			yes	yes	yes	yes
Low-temperature (**) boiler			yes	yes	yes	yes
B ₁ boiler			no	no	no	no
Cogeneration space heater			no	no	no	no
Combination heater			yes	yes	yes	yes
Seasonal space heating energy efficiency class			A	A	A	A
Water heating energy efficiency class			A	A	A	A
Declared load profile			M	XL	XL	XL
Item	Symbol	Unit	Value			
Rated heat output	P _{rated}	kW	12	23	26	30
Useful heat output: At rated heat output and high-temperature regime (*)	P ₄	kW	11,8	23,1	26,0	29,6
Useful heat output: At 30 % of rated heat output and low-temperature regime (**)	P ₁	kW	3,9	7,7	8,7	9,8
Seasonal space heating energy efficiency	η _s	%	92	92	92	91
Useful efficiency: At rated heat output and high-temperature regime (*)	η ₄	%	87,2	87,4	87,1	87,5
Useful efficiency: At 30 % of rated heat output and low-temperature regime (**)	η ₁	%	97,4	97,6	96,6	96,2
Auxiliary electricity consumption: At full load	e _{l,max}	kW	0,023	0,043	0,048	0,055
Auxiliary electricity consumption: At part load	e _{l,min}	kW	0,012	0,013	0,014	0,015
Auxiliary electricity consumption: In standby mode	P _{SB}	kW	0,003	0,003	0,003	0,003
Standby heat loss	P _{stby}	kW	0,050	0,050	0,060	0,064
Ignition burner power consumption	P _{ign}	kW	0,000	0,000	0,000	0,000
Annual energy consumption	Q _{HE}	GJ	22	41	46	53
Emissions of nitrogen oxides	NO _x	mg/kWh	20	29	33	36
Sound power level, indoors	L _{WA}	dB(A)	48	52	52	53
Water heating energy efficiency	η _{wh}	%	80	84	84	85
Daily electricity consumption	Q _{elec}	kWh	0,079	0,143	0,137	0,136
Annual electricity consumption	AEC	kWh	17	31	29	29
Daily fuel consumption	Q _{fuel}	kWh	7,480	23,317	23,252	23,047
Annual fuel consumption	AFC	GJ	6	18	18	17
Contact details: FONDITAL S.p.A. - Via Cerreto, 40 I-25079 VOBARNO (Brescia) Italia - Italy						
(*) High-temperature regime means 60 °C return temperature at heater inlet and 80 °C feed temperature at heater outlet.						
(**) Low temperature means for condensing boilers 30 °C, for low-temperature boilers 37 °C and for other heaters 50 °C return temperature (at heater inlet).						

Tab. 12 ERP and Labelling data - KC

Model(s): ANTEA NEXT			KR 12 KRB 12	KR 24 KRB 24	KR 28 KRB 28	KR 32 KRB 32
Condensing boiler			yes	yes	yes	yes
Low-temperature (**) boiler			yes	yes	yes	yes
B ₁ boiler			no	no	no	no
Cogeneration space heater			no	no	no	no
Combination heater			no	no	no	yes
Seasonal space heating energy efficiency class			A	A	A	A
Item	Symbol	Unit	Value			
Rated heat output	P _{rated}	kW	12	23	26	30
Useful heat output: At rated heat output and high-temperature regime (*)	P ₄	kW	11,8	23,1	26,0	29,6
Useful heat output: At 30 % of rated heat output and low-temperature regime (**)	P ₁	kW	3,9	7,7	8,7	9,8
Seasonal space heating energy efficiency	η _s	%	92	92	92	91
Useful efficiency: At rated heat output and high-temperature regime (*)	η ₄	%	87,2	87,4	87,1	87,5
Useful efficiency: At 30 % of rated heat output and low-temperature regime (**)	η ₁	%	97,4	97,6	96,6	96,2
Auxiliary electricity consumption: At full load	e _{l,max}	kW	0,023	0,043	0,048	0,055
Auxiliary electricity consumption: At part load	e _{l,min}	kW	0,012	0,013	0,014	0,015
Auxiliary electricity consumption: In standby mode	P _{SB}	kW	0,003	0,003	0,003	0,003
Standby heat loss	P _{stby}	kW	0,050	0,050	0,060	0,064
Ignition burner power consumption	P _{ign}	kW	0,000	0,000	0,000	0,000
Annual energy consumption	Q _{HE}	GJ	22	41	46	53
Emissions of nitrogen oxides	NO _x	mg/kWh	20	29	33	36
Sound power level, indoors	L _{WA}	dBA	48	52	52	53
Contact details: FONDITAL S.p.A. - Via Cerreto, 40 I-25079 VOBARNO (Brescia) Italia - Italy						
(*) High-temperature regime means 60 °C return temperature at heater inlet and 80 °C feed temperature at heater outlet.						
(**) Low temperature means for condensing boilers 30 °C, for low-temperature boilers 37 °C and for other heaters 50 °C return temperature (at heater inlet).						

Tab. 13 ERP and Labelling data - KR/KRB

2. Instructions for the installer



WARNING

**The information in this section of the manual is for qualified personnel only.
The user is not authorised to carry out such operations.**

2.1 Installation standards

This boiler must be installed in compliance with the laws and standards in force in the country of installation, which are herein considered as entirely transcribed.

To find out about the gas category and technical specifications, refer to operation data and general features specified in the previous pages.



DANGER

**Accessories and spare parts for installation and service procedures are to be supplied by the Manufacturer.
Should non-original accessories and spare parts be employed, boiler proper performance is not guaranteed.**

2.1.1 Packaging

Boiler is shipped in a sturdy cardboard box.

Remove boiler from cardboard box and check its integrity.

The packing materials can be recycled. Disposal must be managed via appropriate waste collection sites.

Keep packaging out of reach of children, as it may be dangerous.

The manufacturer shall not be held responsible in case of damage to people, animals, or property due to failure to follow the above mentioned instructions.

Packaging includes:

- a wall bracket.
- one temperature probe for water heater (KRB, only).
- a bag containing:
 - » boiler use manual;
 - » this boiler installation and maintenance manual;
 - » 2 screws and relevant wall blocks for fixing the boiler to the wall;
 - » the template for mounting the boiler on a wall (see Fig. 7 Paper template).

2.2 Choosing where to install the boiler

The following must be taken into account when choosing where to install the boiler:

- indications contained in paragraph *Air intake and flue gas venting system* on page 27 and its sub-paragraphs.
- check the wall for sturdiness, avoiding weak areas.
- do not install the boiler over appliances which may affect boiler operation (e.g. cookers, which produce steam and grease, washing machines etc.).
- do not install boilers in locations with a corrosive or very dusty atmosphere, such as hairdresser salons, laundries etc., as this may severely reduce the lifespan of the components of the boiler.
- avoid installing the air intake terminal in rooms or areas with corrosive or very dusty atmosphere to protect the heat exchanger.

2.3 Positioning the boiler

Each boiler is supplied with a paper template, found inside the packaging (see Fig. 7 Paper template).

The template allows you to ensure that the pipes connected to the CH system, the DHW system and the gas mains, and the air intake/flue gas venting ducts are all laid out correctly during the realisation of the water system and before installation of the boiler.

This template is made of heavy-duty paper and must be fixed, with the help of a level, onto the wall where the boiler is to be mounted. The template provides all the indications required to drill the boiler mounting holes to the wall, procedure which is done using two screws and expansion blocks.

The lower area of the template shows where to mark the exact point at which the couplings are to be positioned for boiler connection to the gas supply pipe, cold water mains supply pipe, hot water outlet, CH flow and return pipes.

The upper area of the template shows where air intake and flue gas venting pipes are to be positioned.

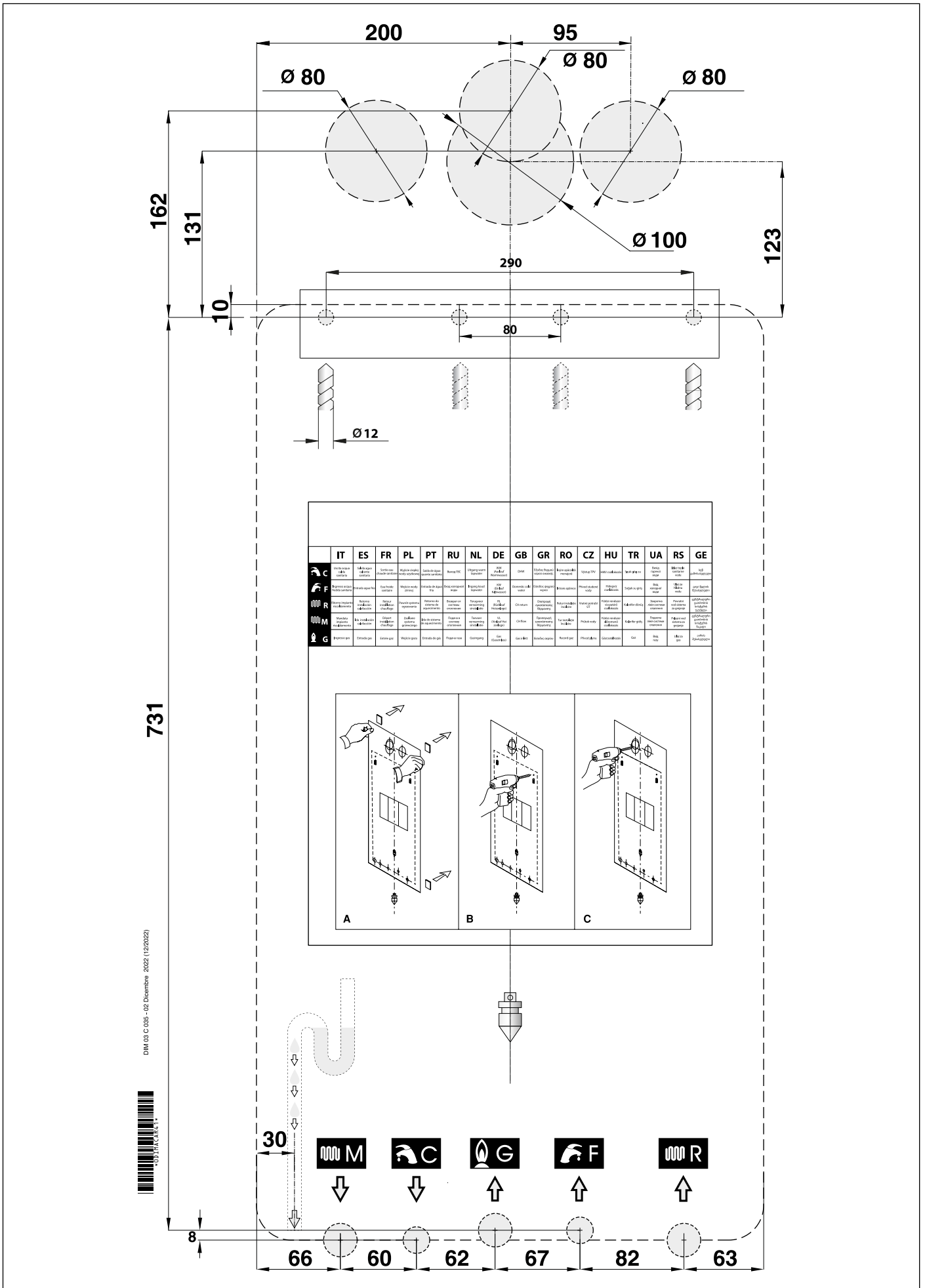

Fig. 7 Paper template

2.4 Minimum installation distances

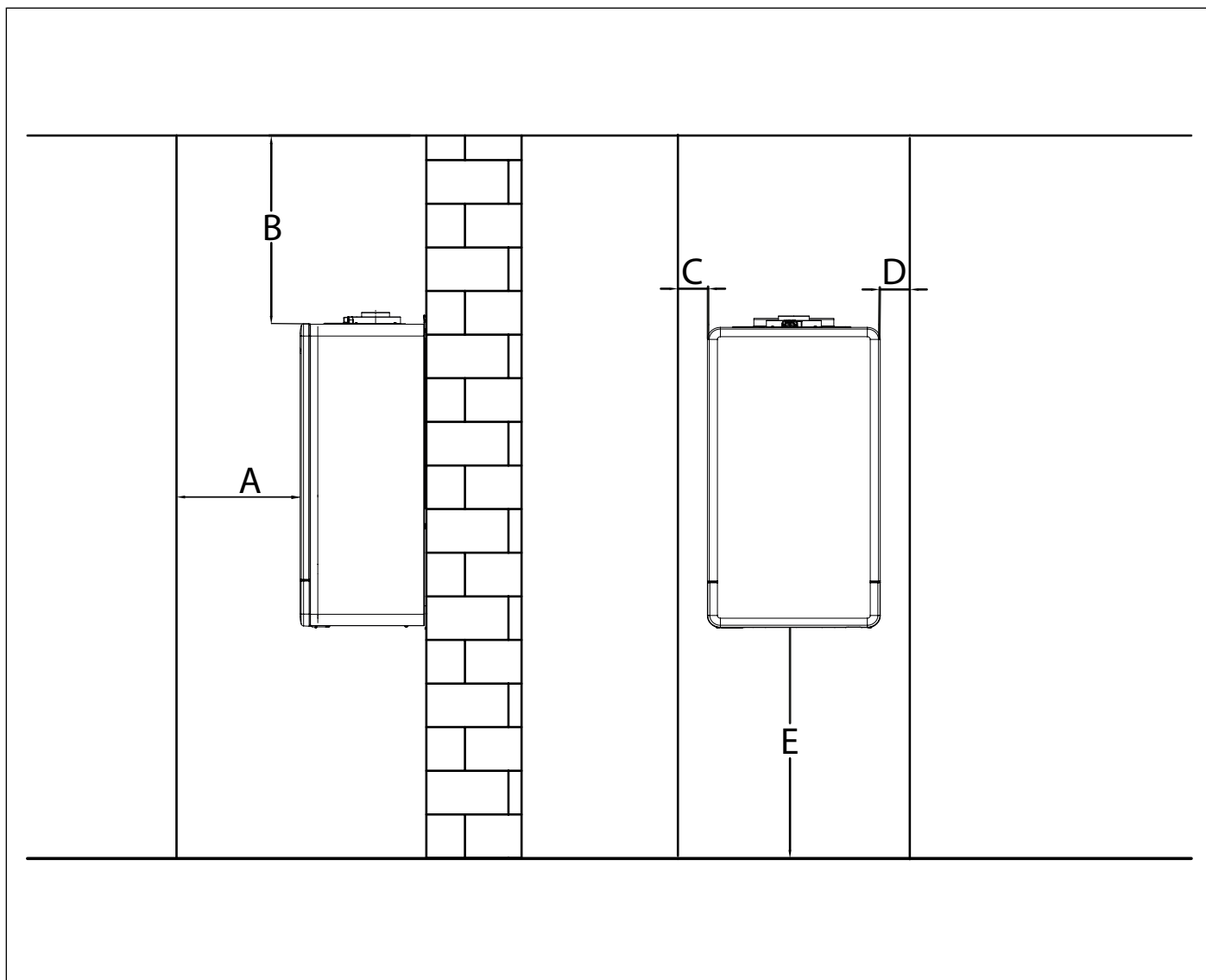

Fig. 8 Minimum installation distances

Ref	Minimum distances [mm]
A	450
B	350
C	50
D	50
E	350

2.5 Installing the boiler



DANGER

Before connecting the boiler to CH and DHW system pipes, clean the latter carefully.

Before commissioning a NEW system, clean it to remove any metal chips due to machining and welding, and any oil and grease that might negatively affect boiler operation or even damage it in case they get inside it.

Before commissioning a RECONDITIONED system (where radiators have been added, the boiler has been replaced, etc.) thoroughly clean it to remove any sludge and residues.

Clean the system using standard non-acid products, available on the market.

Do not use solvents as they could damage system components.

Furthermore, in the central heating system (either new or reconditioned), it is always advisable to add to water a suitable percentage of corrosion protectants for multi-metal systems that will create a protective film onto all internal surfaces.

The manufacturer shall not be held responsible in case of damage to people, animals, or property due to failure to follow the above mentioned instructions.



DANGER

For all boiler installation types, it is necessary to install a filter which can be inspected (Y-shaped type) with Ø 0.4mm-mesh, on the return pipe before the boiler.

In order to install the boiler proceed as follows:

- Affix the template to the wall.
- Drill two Ø 12 mm holes in the wall to accommodate the boiler bracket wall blocks.
- If necessary, provide holes in the wall to allow air intake and/or flue gas venting ducts to pass through it.
- Secure the supporting bracket to the wall using the blocks supplied with the boiler.
- With reference to the lower part of the template, position the fittings for the connection of:
 - » gas supply pipe **G**;
 - » cold water supply pipe (KC/KR) or return pipe of water heater (KRB) **F**;
 - » DHW outlet (KC) or flow pipe of water heater (KRB) **C**;
 - » CH flow pipe **M**;
 - » CH return pipe **R**.
- Provide a condensate drain and an outlet for the 3-bar safety valve.
- Hook boiler to supporting bracket.
- Connect the boiler to the feed pipes (see *Hydraulic connections* on page 43).
- Connect the boiler to the condensate drain system (refer to *Hydraulic connections* on page 43).
- Connect the boiler to the outlet system of the 3-bar safety valve.
- Connect the boiler to the air intake and flue gas venting system (see *Air intake and flue gas venting system* on page 27).
- Connect power supply, ambient thermostat (when available) and other available accessories (refer to the following paragraphs).

2.6 Boiler room ventilation

The boiler has sealed combustion chamber. Combustion air is not drawn from boiler room, therefore no specific recommendations need to be applied concerning the boiler room or openings and ventilation provided to the boiler room.



DANGER

The boiler must be installed in a room that is compliant with the legislation and standards in force in the country of installation, which are herein considered as entirely transcribed.

2.7 Air intake and flue gas venting system

Flue gas discharge into the atmosphere and air intake/flue gas venting systems must comply with applicable laws and standards in the country of installation that are considered as fully transcribed herein.



DANGER

For the air intake/flue gas venting systems, specific, manufacturer-approved, condensate acid-resistant pipes and systems must be used, suitable for condensing boilers.



DANGER

In the case of passages through walls with split or coaxial air intake and gas venting ducts, always seal any space between pipes and walls.

If the wall is made of flammable material, apply fireproof insulating material around the flue gas venting pipe.



DANGER

For boilers with split air intake and flue gas venting ducts, in the case of passages through flammable walls, apply fireproof insulating material around the flue gas venting pipe.



DANGER

The boiler is equipped with a safety device for flue gas exhaustion check.

It is strictly forbidden to tamper with and/or prevent operation of such safety device.

Should an air intake/flue gas system malfunction occur, the device will shut down the boiler by interrupting the gas supply to the boiler and the LCD will display the E03 code.

In this case it is necessary to have safety device, boiler and the air intake/flue gas venting ducts promptly checked by a service centre or a qualified service engineer.

In case of repeated stops, it is necessary to have safety device, boiler and the air intake/flue gas venting ducts checked by a service centre or a qualified service engineer.

After each operation on the safety device or the air intake/flue gas venting system, it is necessary to perform a functional test of the boiler.

In case it is necessary to replace the safety device use only original spare parts supplied by the Manufacturer.

To reset the combustion gas exhaust control device operation it is necessary to press "Reset".

2.7.1 Starter kit installation

Refer to Fig. 9 Split kit installation and to Fig. 10 Coaxial kit installation.



DANGER

There must be no leakage of combustion by-products from any of the gaskets.

Split kit (optional)

Clean the boiler roof from dust and other debris due to any masonry works.

Fix the adhesive gasket under the flange connection for flue gas venting system (A). The gasket must adhere completely to the whole surface.

Fix the flange connection for flue gas venting system (A) on the boiler roof at the suitable hole, using the screws supplied. The gasket must adhere completely to the roof surface.

Remove one of the two flue gas closing caps (C) from the boiler roof eliminating any seal residues.

Fix the adhesive gasket under the flange connection for air intake system (B). The gasket must adhere completely to the whole surface.

Fix the flange connection for air intake system (B) on the boiler roof at the suitable hole, using the screws supplied. The gasket must adhere completely to the roof surface.

Coaxial kit (optional)

Clean the boiler roof from dust and other debris due to any masonry works.

Fix the adhesive gasket under the flange coaxial connection (D). The gasket must adhere completely to the whole surface.

Fix the flange coaxial connection (D) at the suitable hole on the boiler roof, using the screws supplied. The gasket must adhere completely to the roof surface.

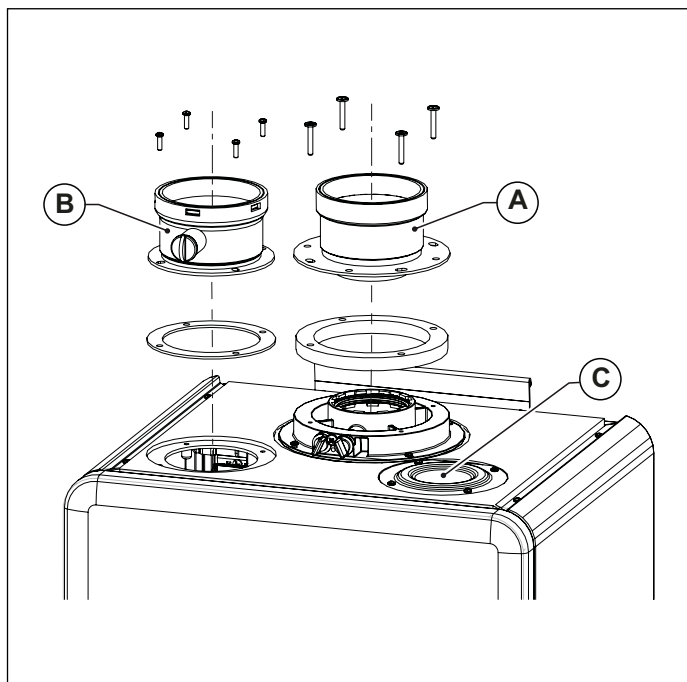

Fig. 9 Split kit installation

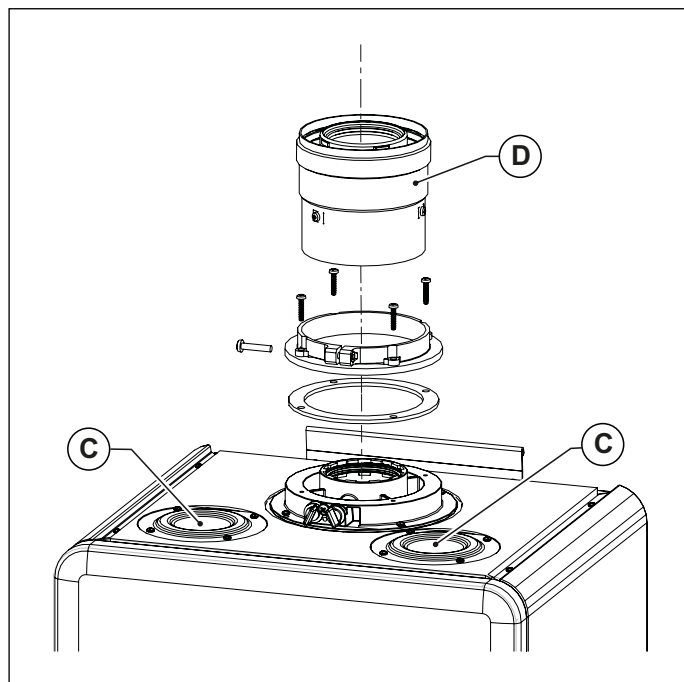

Fig. 10 Coaxial kit installation

2.7.2 Pipe and terminal installation



DANGER

Flue gas venting pipes are to be installed tilted toward the boiler so that condensate runs toward the combustion chamber, which is designed for condensate collection and drainage.

Should the above procedure not be possible, it is necessary to install, in condensate stagnation areas, devices designed for condensate collection and conveying to the condensate drain system.

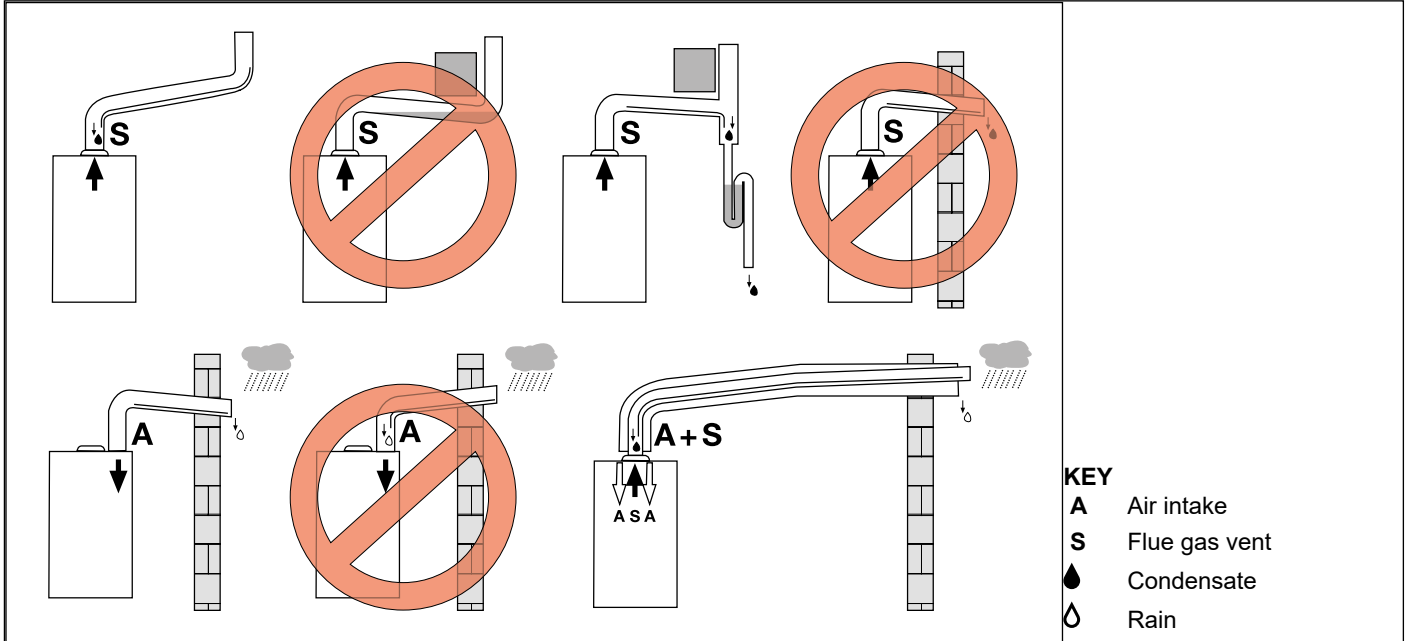

Fig. 11 Installation examples

To install pipes, elbows, terminals and other accessories for air intake and flue gas venting, proceed as follows (see Fig. 12 Pipe installation):

- Clean surfaces and gaskets of the components, removing any dust and debris.
- Apply a thin layer of lubricant on the gasket.
- Insert the components with a slight rotation, pushing until the spigot end stops.



DANGER

There must be no leakage of combustion by-products from any of the gaskets.

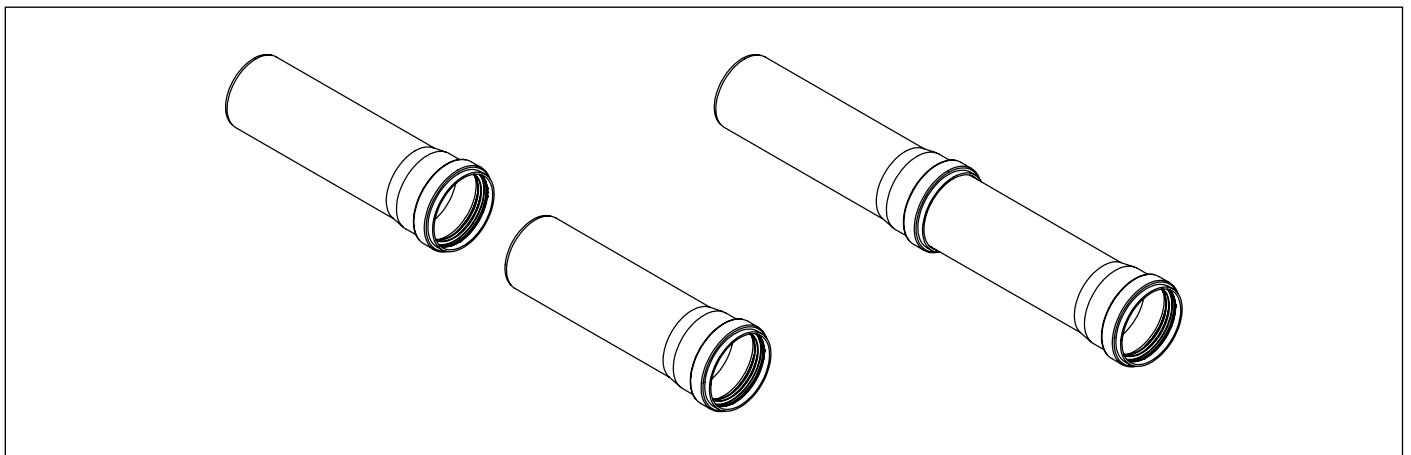

Fig. 12 Pipe installation

Wall-mounted terminals

The final parts of air intake and flue gas venting terminals, both split and coaxial, feature a groove (A) to fix the external collar (see Fig. 13 Wall-mounted terminal installation).

Insert the external collar into the terminal until reaching the groove.

Insert the terminal, from outside, making the external collar adhere to the wall. The terminal projection beyond the wall must be that imposed by the collar forced position.

Insert the internal collar, from inside, until it adheres to the wall.

Any pipes, elbows or other components must not be inserted at the passage through the wall.

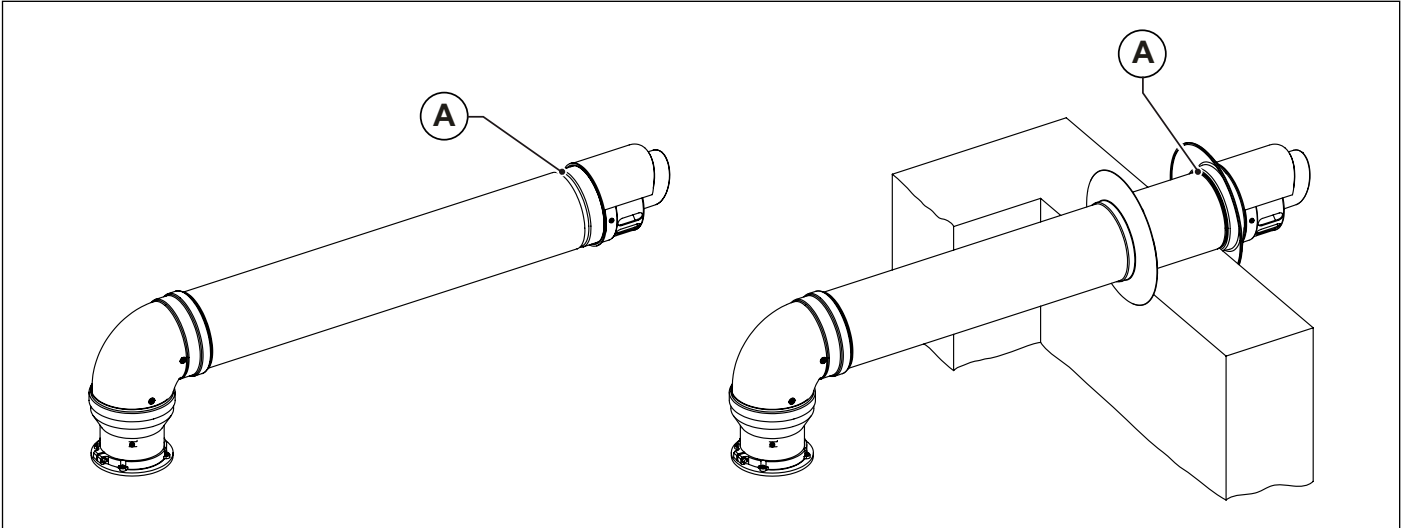

Fig. 13 Wall-mounted terminal installation

Tile for pitched roofs

The tile for pitched roofs can be used on roofs with an inclination between 18° and 44° (see Fig. 14 Tile for pitched roofs).

Remove the roofing elements (tiles, pantiles,...) from the roof area where the tile for pitched roofs will be installed.

Position the tile on the roof.

Position the roofing elements (tiles, pantiles,...) in such a way that rainwater drains over them.

Fit the cap (A) on the tile. The cap can be fitted in 2 positions, according to the roof inclination.

Insert the flue from above through the tile.

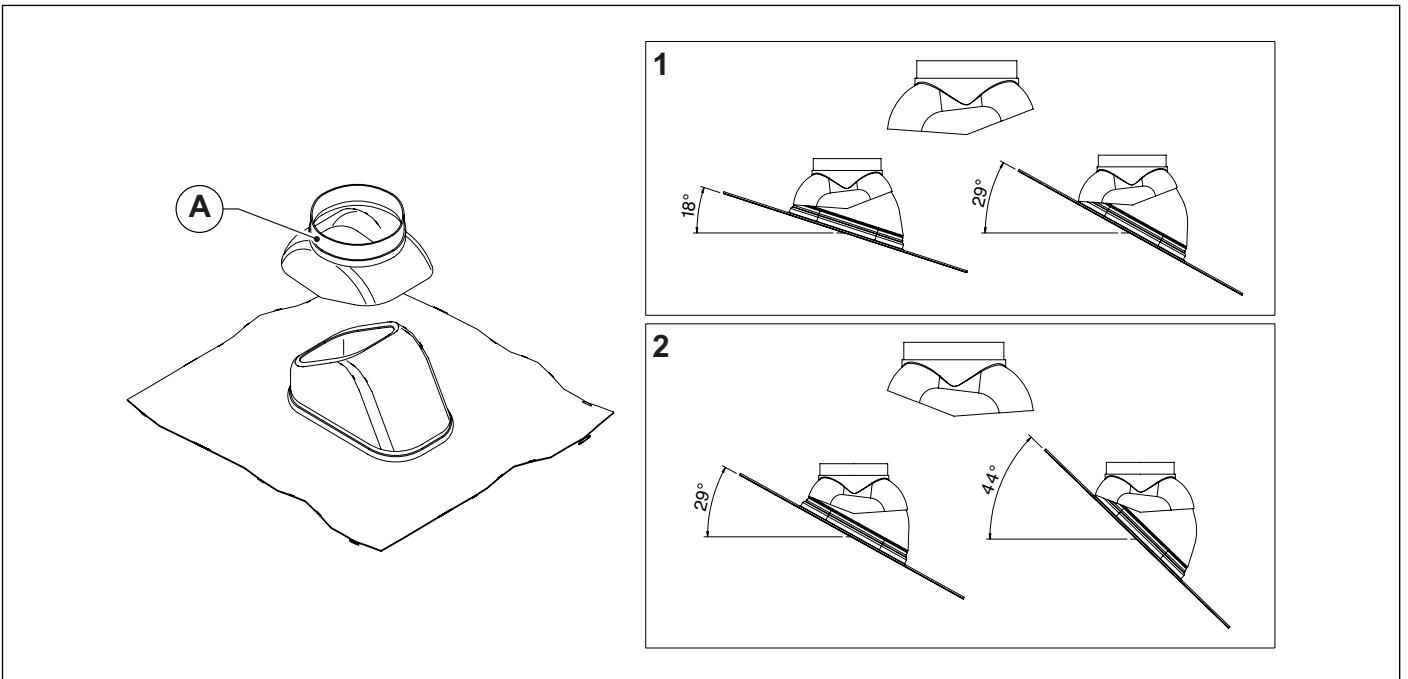

Fig. 14 Tile for pitched roofs

Roof flues

Insert the air intake and/or flue gas venting flue from above through the tile.

Position the rainproof collar (A) until it bottoms on the cap of the tile for roofs (B) and fix it with the screw supplied.

Keep the distance indicated in the figure between the rainproof collar and the terminal.

Check that the flue is in a vertical position and fix it to the structure with collars or other fixing systems.

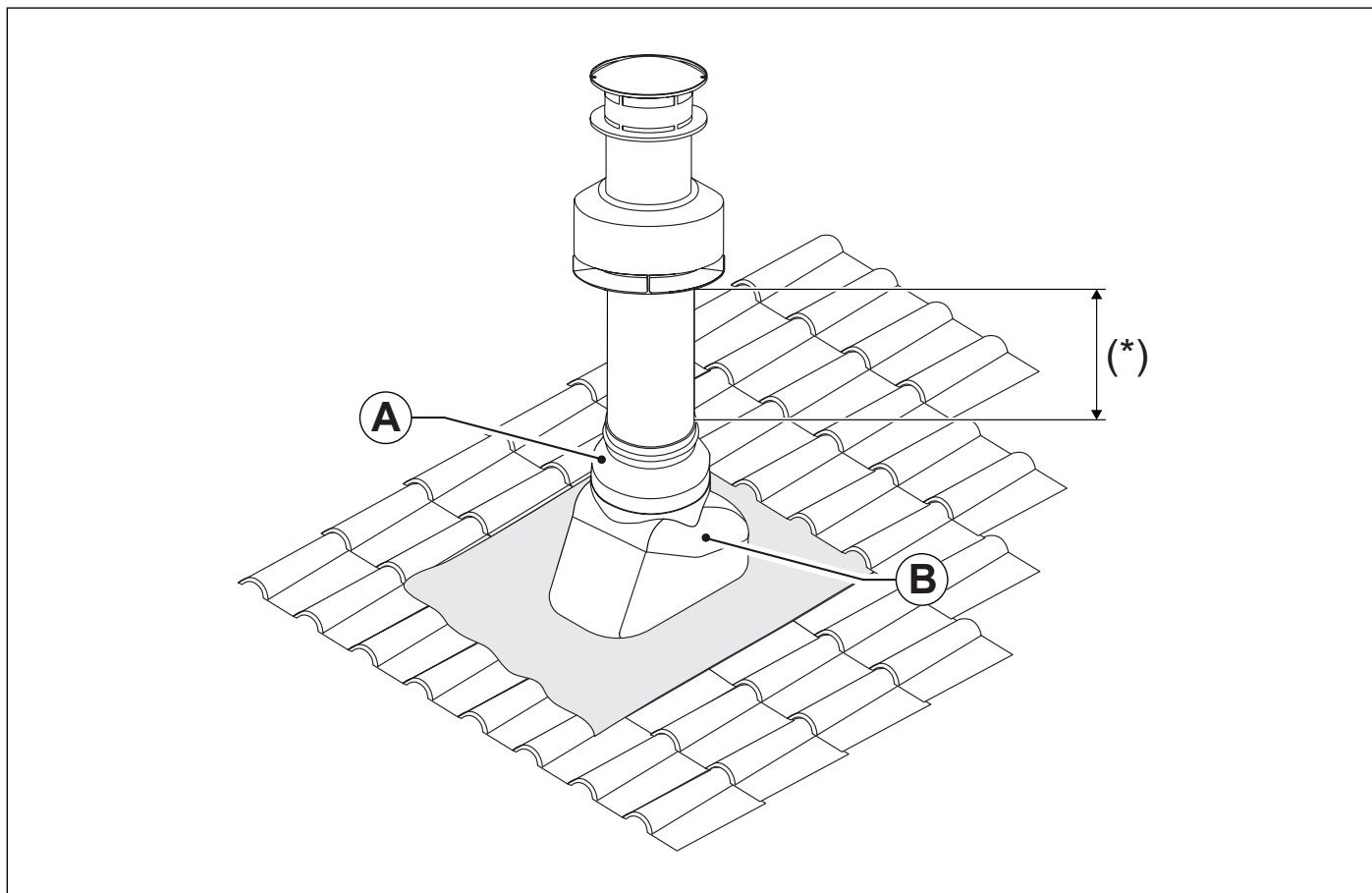

Fig. 15 Roof flue installation

(*) ≥ 370 mm for 0CAMISCA00 and 0CAMIASP00 accessories.
= 270 mm for 0KCAMASP00 accessory.

2.7.3 Possible configuration of air intake and flue gas venting ducts

Type B23/B23P

Boiler intended for connection to an existing flue system external to the boiler room.

Combustion air is taken directly from the boiler room itself while flue gas is conveyed to the outside.

The boiler is not to be fitted with anti-wind gust device; it has to be equipped with a fan mounted before the combustion chamber/heat exchanger.

Type B33

Boiler intended for connection to an existing flue system external to the boiler room.

Combustion air is taken directly from the boiler room itself while flue gas is conveyed to the outside.

The boiler is not to be fitted with anti-wind gust device; it has to be equipped with a fan mounted before the combustion chamber/heat exchanger.

All parts of the equipment in contact with the combustion by-products are hermetically sealed by the parts of the equipment intended for the supply of combustion air.

Combustion air is conveyed to the equipment from the installation environment by means of a concentric duct to the combustion by-products venting duct.

Combustion air enters the duct thanks to the presence of suitable openings positioned on the surface of the duct itself.

Type C13/C13X

Boiler intended for connection to horizontal outlet and intake ducts connected to the outside by means of coaxial or split ducts.

The minimum distance between the air intake duct and the flue gas venting duct must be at least 250 mm, whereas both terminals must be contained within a square measuring 500 x 500 mm.

The boiler is to be equipped with a fan mounted before the combustion chamber/heat exchanger.

Type C33/C33X

Boiler intended for connection to vertical outlet and intake ducts connected to the outside by means of coaxial or split ducts.

The minimum distance between the air intake duct and the flue gas venting duct must be at least 250 mm, whereas both terminals must be contained within a square measuring 500 x 500 mm.

The boiler is to be equipped with a fan mounted before the combustion chamber/heat exchanger.

Type C43/C43X

Boiler intended for connection to collective chimney pipe system that includes two ducts, one for air intake and the other for flue gas exhaust. These ducts may be coaxial or split.

The chimney must be compliant with applicable legislation and standards.

The boiler is to be equipped with a fan mounted before the combustion chamber/heat exchanger.

Type C53/C53X

Boiler with separate pipes for combustion air intake and flue gas evacuation.

These pipes may discharge in areas at a different pressure.

The terminals may not face each other from opposed walls.

The boiler is to be equipped with a fan mounted before the combustion chamber/heat exchanger.

Type C63/C63X

Boiler designed to be sold without air intake or flue gas venting ducts.

Flue gas venting and air intake to be ensured by using commercially available pipes, which are to be certified separately.

The boiler is to be equipped with a fan mounted before the combustion chamber/heat exchanger.

Type C83/C83X

Boiler intended to be connected to combustion air terminal and to a single flue gas terminal or collective chimney.

The chimney must be compliant with applicable legislation and standards.

The boiler is to be equipped with a fan mounted before the combustion chamber/heat exchanger.

Type C93/C93X

Boiler designed to be connected to a vertical terminal through a ducted vent duct.

The technical compartment where the venting system is housed is also used as combustion air intake duct, through the air gap which is created.

The boiler is to be equipped with a fan mounted before the combustion chamber/heat exchanger.

2.7.4 Length of air intake and flue gas venting ducts

Lengths are expressed in equivalent metres on flue gas vent (m_{sef}).

To calculate the actual length of the air intake/flue gas vent system, flow resistances of the accessories must be used (see *Flow resistance tables* on page 37).



WARNING

The information given above is with reference to air intake/flue gas venting ducts made from smooth, rigid pipes approved and supplied by the manufacturer.

In the case of both horizontal and vertical coaxial vent pipes, the minimum permitted length is 1 metre.

In the case of split pipes for both the vent and suction pipes, the minimum permissible length is 1 metre.



WARNING

In the case of horizontal coaxial vent pipes the air intake duct is to be tilted down by 1% toward its exit, in order to avoid water to enter it.

KC 18 - KR/KRB 12

Type of installation	Intake pipe diameter [mm]	Vent pipe diameter [mm]	um	Max intake length L_A	Max venting length L_S	Max total length $L_A + L_S$
B23/B23P	-	Ø 80	m_{sef}	-	196	196
	-	Ø 80 + Ø 60				
	-	Ø 80 + Ø 50				
C43/C43X	Ø 80	Ø 80	m_{sef}	196	196	196
C53/C53X	Ø 80	Ø 80 + Ø 60				
C83/C83X	Ø 80	Ø 80 + Ø 50				
C13/C13X (*)	Ø 60/100		m_{sef}	-	-	15
C33/C33X	Ø 80/125		m_{sef}	-	-	36
C63/C63X	Residual flue head ($P_{\text{min}}-P_{\text{max}}$): 4 - 168 Pa					
C93/C93X	Ø 80/125 + Ø 80 (1) □ minimum 133x133 Ø minimum 150		m	-	41	41
	Ø 60/100 + Ø 60 (2) □ minimum 113x113 Ø minimum 128		m	-	36	36
	Ø 60/100 + Ø 50 (3) □ minimum 108x108 Ø minimum 122		m	-	17	17

Tab. 14 Pipe length KC 18 - KR/KRB 12

(*) the flow resistance of the first elbow shall not be taken into account to calculate maximum permissible length.

m_{sef} = equivalent metres on flue gas vent

m = linear metres

(1) Maximum length that can be developed in a lightwell with the specified minimum size (133x133 mm or Ø 150 mm), including terminal C9. The fitting with the boiler is composed of a 60/100 - 80/125 mm adapter, a 90° elbow with 80/125 mm diameter and a one-metre extension with 80/125 mm diameter.

(2) Maximum length that can be developed in a lightwell with the specified minimum size (113x113 mm or Ø 128 mm), including terminal C9. The fitting with the boiler is composed of a 90° elbow with 60/100 mm diameter and a one-metre extension with 60/100 mm diameter.

(3) Maximum length that can be developed in a lightwell with the specified minimum size (108x108 mm or Ø 122 mm), including terminal C9. The fitting with the boiler is composed of a 90° elbow with 60/100 mm diameter and a one-metre extension with 60/100 mm diameter and a 60-50 adapter.

KC 26 - KR/KRB 24

Type of installation	Intake pipe diameter [mm]	Vent pipe diameter [mm]	um	Max intake length L_A	Max venting length L_S	Max total length $L_A + L_S$
B23/B23P	-	Ø 80	m_{sef}	-	139	139
	-	Ø 80 + Ø 60				
	-	Ø 80 + Ø 50				
C43/C43X	Ø 80	Ø 80	m_{sef}	139	139	139
C53/C53X	Ø 80	Ø 80 + Ø 60				
C83/C83X	Ø 80	Ø 80 + Ø 50				
C13/C13X (*)	Ø 60/100		m_{sef}	-	-	15,5
C33/C33X	Ø 80/125		m_{sef}	-	-	38
C63/C63X	Residual flue head (Pmin-Pmax): 8 - 250 Pa					
C93/C93X	Ø 80/125 + Ø 80 (1) □ minimum 133x133 Ø minimum 150		m	-	42	42
	Ø 60/100 + Ø 60 (2) □ minimum 113x113 Ø minimum 128		m	-	28	28
	Ø 60/100 + Ø 50 (3) □ minimum 108x108 Ø minimum 122		m	-	11	11

Tab. 15 Pipe length KC 26 - KR/KRB 24

(*) the flow resistance of the first elbow shall not be taken into account to calculate maximum permissible length.

m_{sef} = equivalent metres on flue gas vent

m = linear metres

(1) Maximum length that can be developed in a lightwell with the specified minimum size (133x133 mm or Ø 150 mm), including terminal C9. The fitting with the boiler is composed of a 60/100 - 80/125 mm adapter, a 90° elbow with 80/125 mm diameter and a one-metre extension with 80/125 mm diameter.

(2) Maximum length that can be developed in a lightwell with the specified minimum size (113x113 mm or Ø 128 mm), including terminal C9. The fitting with the boiler is composed of a 90° elbow with 60/100 mm diameter and a one-metre extension with 60/100 mm diameter.

(3) Maximum length that can be developed in a lightwell with the specified minimum size (108x108 mm or Ø 122 mm), including terminal C9. The fitting with the boiler is composed of a 90° elbow with 60/100 mm diameter and a one-metre extension with 60/100 mm diameter and a 60-50 adapter.

KC 30 - KR/KRB 28

Type of installation	Intake pipe diameter [mm]	Vent pipe diameter [mm]	um	Max intake length L _A	Max venting length L _S	Max total length L _A + L _S
B23/B23P	-	Ø 80	m _{sef}	-	111	111
	-	Ø 80 + Ø 60				
	-	Ø 80 + Ø 50				
C43/C43X	Ø 80	Ø 80	m _{sef}	111	111	111
C53/C53X	Ø 80	Ø 80 + Ø 60				
C83/C83X	Ø 80	Ø 80 + Ø 50				
C13/C13X (*)	Ø 60/100		m _{sef}	-	-	15,5
C33/C33X	Ø 80/125		m _{sef}	-	-	38
C63/C63X	Residual flue head (Pmin-Pmax): 7 - 237 Pa					
C93/C93X	Ø 80/125 + Ø 80 (1) □ minimum 133x133 Ø minimum 150		m	-	42	42
	Ø 60/100 + Ø 60 (2) □ minimum 113x113 Ø minimum 128		m	-	20	20
	Ø 60/100 + Ø 50 (3) □ minimum 108x108 Ø minimum 122		m	-	8	8

Tab. 16 Pipe length KC 30 - KR/KRB 28

(*) the flow resistance of the first elbow shall not be taken into account to calculate maximum permissible length.

m_{sef} = equivalent metres on flue gas vent

m = linear metres

(1) Maximum length that can be developed in a lightwell with the specified minimum size (133x133 mm or Ø 150 mm), including terminal C9. The fitting with the boiler is composed of a 60/100 - 80/125 mm adapter, a 90° elbow with 80/125 mm diameter and a one-metre extension with 80/125 mm diameter.

(2) Maximum length that can be developed in a lightwell with the specified minimum size (113x113 mm or Ø 128 mm), including terminal C9. The fitting with the boiler is composed of a 90° elbow with 60/100 mm diameter and a one-metre extension with 60/100 mm diameter.

(3) Maximum length that can be developed in a lightwell with the specified minimum size (108x108 mm or Ø 122 mm), including terminal C9. The fitting with the boiler is composed of a 90° elbow with 60/100 mm diameter and a one-metre extension with 60/100 mm diameter and a 60-50 adapter.

KC 35 - KR/KRB 32

Type of installation	Intake pipe diameter [mm]	Vent pipe diameter [mm]	um	Max intake length L_A	Max venting length L_S	Max total length $L_A + L_S$
B23/B23P	-	Ø 80	m_{sef}	-	85	85
	-	Ø 80 + Ø 60				
	-	Ø 80 + Ø 50				
C43/C43X	Ø 80	Ø 80	m_{sef}	85	85	85
C53/C53X	Ø 80	Ø 80 + Ø 60				
C83/C83X	Ø 80	Ø 80 + Ø 50				
C13/C13X (*)	Ø 60/100		m_{sef}	-	-	14
C33/C33X	Ø 80/125		m_{sef}	-	-	42
C63/C63X	Residual flue head (Pmin-Pmax): 8.8 - 222 Pa					
C93/C93X	Ø 80/125 + Ø 80 (1) □ minimum 133x133 Ø minimum 150		m	-	42	42
	Ø 60/100 + Ø 60 (2) □ minimum 113x113 Ø minimum 128		m	-	18	18
	Ø 60/100 + Ø 50 (3) □ minimum 108x108 Ø minimum 122		m	-	7	7

Tab. 17 Pipe length KC 35 - KR/KRB 32

(*) the flow resistance of the first elbow shall not be taken into account to calculate maximum permissible length.

m_{sef} = equivalent metres on flue gas vent

m = linear metres

(1) Maximum length that can be developed in a lightwell with the specified minimum size (133x133 mm or Ø 150 mm), including terminal C9. The fitting with the boiler is composed of a 60/100 - 80/125 mm adapter, a 90° elbow with 80/125 mm diameter and a one-metre extension with 80/125 mm diameter.

(2) Maximum length that can be developed in a lightwell with the specified minimum size (113x113 mm or Ø 128 mm), including terminal C9. The fitting with the boiler is composed of a 90° elbow with 60/100 mm diameter and a one-metre extension with 60/100 mm diameter.

(3) Maximum length that can be developed in a lightwell with the specified minimum size (108x108 mm or Ø 122 mm), including terminal C9. The fitting with the boiler is composed of a 90° elbow with 60/100 mm diameter and a one-metre extension with 60/100 mm diameter and a 60-50 adapter.

2.7.5 Flow resistance tables

Flow resistance of separate ducts Ø 80 mm (in equivalent metres on flue gas vent (m_{set}))

Component	Code	KC 18 KR 12 KRB 12		KC 26 KR 24 KRB 24		KC 30 KR 28 KRB 28		KC 35 KR 32 KRB 32	
		A	S	A	S	A	S	A	S
		DN 80 Extension L=1000 mm	0PROLUNG00	0,5	1,0	0,5	1,0	0,5	1,0
DN 80 Extension L=500 mm	0PROLUNG01	0,5	0,5	0,5	0,5	0,5	0,5	0,5	0,5
DN 80 90° elbow	0CURVAXX02	0,5	1,0	1,0	1,0	1,0	1,0	1,0	1,5
DN 80 45° elbow	0CURVAXX01	0,5	1,0	0,5	1,0	0,5	1,0	0,5	1,0
DN 80 T-shaped fitting for visual inspection and condensate collection tank	0KITTRACT00	-	-	-	-	-	-	-	-
DN 80 T-shaped fitting	0RACCORT00	0,5	1,0	0,5	1,0	0,5	1,0	0,5	1,0
DN 80 Telescopic extension L=340...450 mm	0PROLTEL01	0,5	0,5	0,5	0,5	0,5	0,5	0,5	0,5
DN 80 Roof terminal	0CAMISCA00	-	5,0	-	5,5	-	5,5	-	5,5
DN 80 Flexible hose L=20,000 mm	0TUBOFLE01	13,5	20,0	13,0	20,0	13,0	20,0	13,5	20,0
DN 80 Suction opening	0GRIGASP01	5,0	-	5,5	-	5,5	-	6,0	-
DN 80 Flue gas vent terminal L=1000 mm	0TERMSCA00	-	4,5	-	5,0	-	5,0	-	5,0
DN 80/80 Intake/vent terminal on flue gas side	0CAMIASP00	3,5	5,0	4,0	5,5	4,0	5,5	4,0	5,5

Tab. 18 Flow resistance of separate ducts Ø 80 mm

Flow resistance of separate ducts Ø 80 + Ø 50 mm pipework (in equivalent metres on flue gas vent (m_{set}))

Component	Code	KC 18 KR 12 KRB 12		KC 26 KR 24 KRB 24		KC 30 KR 28 KRB 28		KC 35 KR 32 KRB 32	
		A	S	A	S	A	S	A	S
		DN 80 Extension L=1000 mm	0PROLUNG00	0,5	1,0	0,5	1,0	0,5	1,0
DN 80 Extension L=500 mm	0PROLUNG01	0,5	0,5	0,5	0,5	0,5	0,5	0,5	0,5
DN 80 90° elbow	0CURVAXX02	0,5	1,0	1,0	1,0	1,0	1,0	1,0	1,5
DN 80 45° elbow	0CURVAXX01	0,5	1,0	0,5	1,0	0,5	1,0	0,5	1,0
DN 80 T-shaped fitting for visual inspection and condensate collection tank	0KITTRACT00	-	-	-	-	-	-	-	-
DN 80 T-shaped fitting	0RACCORT00	0,5	1,0	0,5	1,0	0,5	1,0	0,5	1,0
DN 80 Telescopic extension L=340...450 mm	0PROLTEL01	0,5	0,5	0,5	0,5	0,5	0,5	0,5	0,5
DN 80 Roof terminal	0CAMISCA00	-	5,0	-	5,5	-	5,5	-	5,5
DN 80 Flexible hose L=20,000 mm	0TUBOFLE01	13,5	20,0	13,0	20,0	13,0	20,0	13,5	20,0
DN 80 Suction opening	0GRIGASP01	5,0	-	5,5	-	5,5	-	6,0	-
DN 80 Flue gas vent terminal L=1000 mm	0TERMSCA00	-	4,5	-	5,0	-	5,0	-	5,0
DN 80/80 Intake/vent terminal on flue gas side	0CAMIASP00	3,5	5,0	4,0	5,5	4,0	5,5	4,0	5,5
DN 50 M-F extension L=1000 mm	0PROLUNG32	7,5	11,0	7,0	11,0	7,0	11,0	7,0	11,0
DN 50 mm 87° elbow	0CURVAXX33	6,5	9,5	7,0	10,5	7,5	11,0	7,5	11,5
DN 50 mm 45° elbow	0CURVAXX34	3,0	4,0	3,0	4,5	3,0	5,0	3,5	5,0
DN 50 Intake terminal L=1000 mm	0TERMASP02	32,0	-	34,0	-	35,0	-	36,0	-
DN 80/DN 50 M/F adapter	0RIDUZIO32	5,0	6,0	5,5	6,5	6,0	6,5	6,0	7,0
DN 50 M/M/F T-shaped fitting	0KITTRACT06	14,0	20,5	15,0	22,5	15,5	23,5	16,5	24,0
DN 50 Flexible hose - 20-metre coil	0TUBOFLE08	146,0	216,5	143,0	218,5	144,5	219,0	146,0	219,5
DN 50 Kit of adapters for flexible hose	0KADAFLE02	-	-	-	-	-	-	-	-
DN 50 Vent terminal L=366 mm	0TERMSCA04	-	18,0	-	20,0	-	20,5	-	21,0
DN 50 Vertical terminal	0TERMTET02	-	12,5	-	14,0	-	14,5	-	14,5
DN 50 Vertical terminal for hose with tile	0TERMTET03	-	16,5	-	18,0	-	18,5	-	19,0

Tab. 19 Flow resistance of separate ducts Ø 80 + Ø 50 mm pipework

A = air intake

S = flue gas vent

Flow resistance of separate ducts Ø 80 + Ø 60 mm pipework (in equivalent metres on flue gas vent (m_{set}))

Component	Code	KC 18		KC 26		KC 30		KC 35	
		KR 12		KR 24		KR 28		KR 32	
		KRB 12	KRB 24	KRB 28	KRB 32	A	S	A	S
		A	S	A	S	A	S	A	S
DN 80 Extension L=1000 mm	0PROLUNG00	0,5	1,0	0,5	1,0	0,5	1,0	0,5	1,0
DN 80 Extension L=500 mm	0PROLUNG01	0,5	0,5	0,5	0,5	0,5	0,5	0,5	0,5
DN 80 90° elbow	0CURVAXX02	0,5	1,0	1,0	1,0	1,0	1,0	1,0	1,5
DN 80 45° elbow	0CURVAXX01	0,5	1,0	0,5	1,0	0,5	1,0	0,5	1,0
DN 80 T-shaped fitting for visual inspection and condensate collection tank	0KITTRACT00	-	-	-	-	-	-	-	-
DN 80 T-shaped fitting	0RACCORT00	0,5	1,0	0,5	1,0	0,5	1,0	0,5	1,0
DN 80 Telescopic extension L=340...450 mm	0PROLTEL01	0,5	0,5	0,5	0,5	0,5	0,5	0,5	0,5
DN 80 Roof terminal	0CAMISCA00	-	5,0	-	5,5	-	5,5	-	5,5
DN 80 Flexible hose L=20,000 mm	0TUBOFLE01	13,5	20,0	13,0	20,0	13,0	20,0	13,5	20,0
DN 80 Suction opening	0GRIGASP01	5,0	-	5,5	-	5,5	-	6,0	-
DN 80 Flue gas vent terminal L=1000 mm	0TERMSCA00	-	4,5	-	5,0	-	5,0	-	5,0
DN 80/80 Intake/vent terminal on flue gas side	0CAMIASP00	3,5	5,0	4,0	5,5	4,0	5,5	4,0	5,5
DN 60 M-F extension L=500 mm	0PROLUNG18	1,5	2,0	1,5	2,0	1,5	2,0	1,5	2,0
DN 60 M-F extension L=1000 mm	0PROLUNG16	3,0	4,0	3,0	4,5	3,0	4,5	3,0	4,5
DN 60 M-F extension L=2000 mm	0PROLUNG17	5,5	8,5	5,5	8,5	5,5	8,5	5,5	8,5
DN 60 mm 87° elbow	0CURVAXX16	1,5	2,5	1,5	2,5	1,5	2,5	2,0	2,5
DN 60 mm 45° elbow	0CURVAXX17	2,0	3,0	2,0	3,0	2,0	3,0	2,0	3,5
DN 60 M/M/F T-shaped fitting	0RACCORT06	6,5	9,5	7,0	10,5	7,0	10,5	7,5	11,0
DN 80/DN 60 M/F adapter	0RIDUZIO19	1,5	0,5	1,5	0,5	1,5	0,5	1,5	1,0
DN 60/DN 80 M/F adapter	0RIDUZIO10	1,5	0,5	1,5	0,5	1,5	0,5	1,5	0,5
DN 60 Flexible hose - 20-metre coil	0TUBOFLE07	57,5	85,0	56,0	85,5	56,5	85,5	57,0	86,0
DN 60 Kit of adapters for flexible hose	0KADAFLE01	-	-	-	-	-	-	-	-
DN 60 Intake terminal L=920 mm	0TERMASP01	15,5	-	16,5	-	17,0	-	17,5	-
DN 60 Vent terminal L=920 mm	0TERMSCA01	-	16,5	-	17,5	-	18,0	-	18,5
DN 60 mm 87° elbow	0CURVAXX22	1,5	2,5	1,5	2,5	1,5	2,5	2,0	2,5
DN 60 mm Suction/vent opening	0YTERCON00	17,0	12,5	18,5	14,0	19,0	14,0	19,5	14,5
DN 60 Plastic roof terminal	0TERMTET04	-	13,0	-	14,0	-	14,5	-	15,0

Tab. 20 Flow resistance of separate ducts Ø 80 + Ø 60 mm pipework

A = air intake

S = flue gas vent

Example of calculation



WARNING

It is compulsory to protect air intake and flue gas vent from the ingress of external objects by means of the appropriate protective terminals/grids.

Maximum 60 mm ducted vertical pipe calculation with 4 m suction and 4 m vent with 80 mm duct before reducing to 60 mm to be ducted on a vertical lightwell.

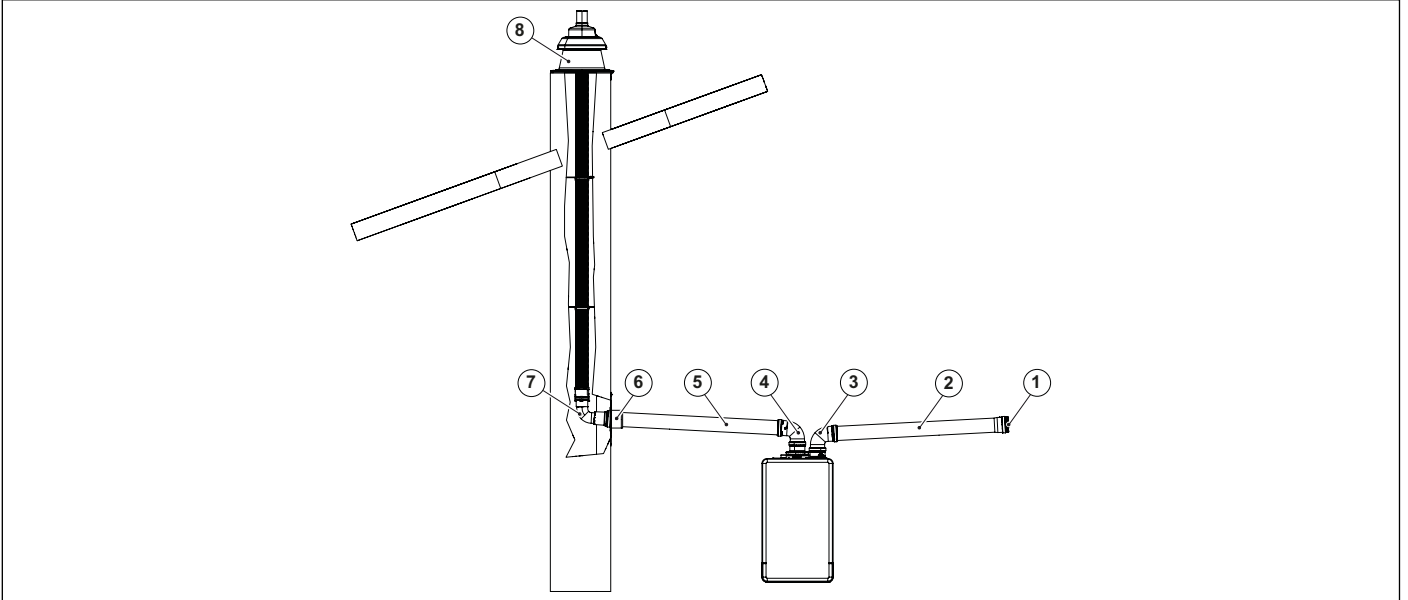

Fig. 16 Split ducts with pipework

Ref	Description	Flue gas kit	Quantity	Equivalent metres			
				KC 18 KR - KRB 12	KC 26 KR - KRB 24	KC 30 KR - KRB 28	KC 35 KR - KRB 32
1	DN 80 Suction opening	0GRIGASP01	1	5,0	5,5	5,5	6,0
2	DN 80 Extension L=1000 mm	0PROLUNG00	4	2,0	2,0	2,0	2,0
3	DN 80 90° elbow	0CURVAXX02	1	0,5	1,0	1,0	1,0
4	DN 80 90° elbow	0CURVAXX02	1	1,0	1,0	1,0	1,5
5	DN 80 Extension L=1000 mm	0PROLUNG00	4	4,0	4,0	4,0	4,0
6	DN 80/DN 60 M/F adapter	0RIDUZIO19	1	0,5	0,5	0,5	1,0
7	DN 60 mm 87° elbow	0CURVAXX16	1	2,5	2,5	2,5	2,5
8	DN 60 Plastic roof terminal	0TERMET04	1	13,0	14,0	14,5	15,0
Total flow resistance				28,5	30,5	31,0	33,0

Tab. 21 Calculation of the maximum ducted 60 mm vertical duct

KC 18 - KR/KRB 12

Total available equivalent metres = 196 m_{sef}

Available residual equivalent metres = (196 - 28.5) = 167.5 m_{sef}

Equivalent flow resistance on a 1m section of Ø60 vent pipe = 4 m_{sef}

Maximum length of vertical section Ø60 (excluding terminal) = 74.5 / 4 = 41.9 m

KC 26 - KR/KRB 24

Total available equivalent metres = 139 m_{sef}

Available residual equivalent metres = (139 - 30.5) = 108.5 m_{sef}

Equivalent flow resistance on a 1m section of Ø60 vent pipe = 4.5 m_{sef}

Maximum length of vertical section Ø60 (excluding terminal) = 108.5 / 4.5 = 24.1 m

KC 30 - KR/KRB 28

Total available equivalent metres = 111 m_{sef}

Available residual equivalent metres = (111 - 31) = 80 m_{sef}

Equivalent flow resistance on a 1m section of Ø60 vent pipe = 4.5 m_{sef}

Maximum length of vertical section Ø60 (excluding terminal) = 80 / 4.5 = 17.8 m

KC 35 - KR/KRB 32

Total available equivalent metres = 85 m_{sef}

Available residual equivalent metres = (85 - 33) = 52 m_{sef}

Equivalent flow resistance on a 1m section of Ø60 vent pipe = 4.5 m_{sef}

Maximum length of vertical section Ø60 (excluding terminal) = 52 / 4.5 = 11.6 m

Flow resistance of concentric ducts Ø 60/100 mm (in equivalent metres on flue gas vent (m_{sef}))

Component	Code	KC 18	KC 26	KC 30	KC 35
		KR 12	KR 24	KR 28	KR 32
		KRB 12	KRB 24	KRB 28	KRB 32
		A + S	A + S	A + S	A + S
DN 60/100 Wall terminal + 90° elbow	0CONDASP00	5,0	5,5	5,5	6,0
DN 60/100 Extension L=1000 mm	0PROLUNG02	1,0	1,0	1,0	1,0
DN 60/100 Extension L=500 mm	0PROLUNG03	0,5	0,5	0,5	0,5
DN 60/100 90° elbow	0CURVAXX05	1,0	1,0	1,0	1,0
DN 60/100 45° elbow	0CURVAXX04	0,5	0,5	0,5	0,5
DN 60/100 Roof vent terminal	0KCAMASP00	4,5	5,0	5,0	5,0

Tab. 22 Flow resistance of concentric ducts Ø 60/100 mm

Flow resistance of concentric ducts Ø 80/125 mm (in equivalent metres on flue gas vent (m_{sef}))

Component	Code	KC 18	KC 26	KC 30	KC 35
		KR 12	KR 24	KR 28	KR 32
		KRB 12	KRB 24	KRB 28	KRB 32
		A + S	A + S	A + S	A + S
DN 60/100-80/125 60/100 to 80/125 adapter	0KITADCO00	1,0	1,0	1,0	1,0
DN 80/125 90° elbow	0CURVAXX07	1,0	1,0	1,0	1,0
DN 80/125 Wall terminal	0KITASCA01	5,0	5,5	6,0	6,0
DN 80/125 Extension L=1000	0PROLUNG04	1,0	1,0	1,0	1,0
DN 80/125 Extension L=500	0PROLUNG05	0,5	0,5	0,5	0,5
DN 80/125 Wall vent coaxial terminal with 60/100-80/125 adapter + 90° elbow + 80/125 terminal	0KITASCA00	7,0	7,5	7,5	8,0
DN 80/125 45° elbow	0CURVAXX06	0,5	1,0	1,0	1,0
DN 80/125 Roof terminal	0KITCACO01	5,5	6,0	6,0	6,0
DN 80/125 Wall vent coaxial terminal with 60/100-80/125 adapter + 80/125 roof terminal	0KITCACO00	6,0	7,0	7,0	7,0

Tab. 23 Flow resistance of concentric ducts Ø 80/125 mm

A + S = air intake + flue gas venting

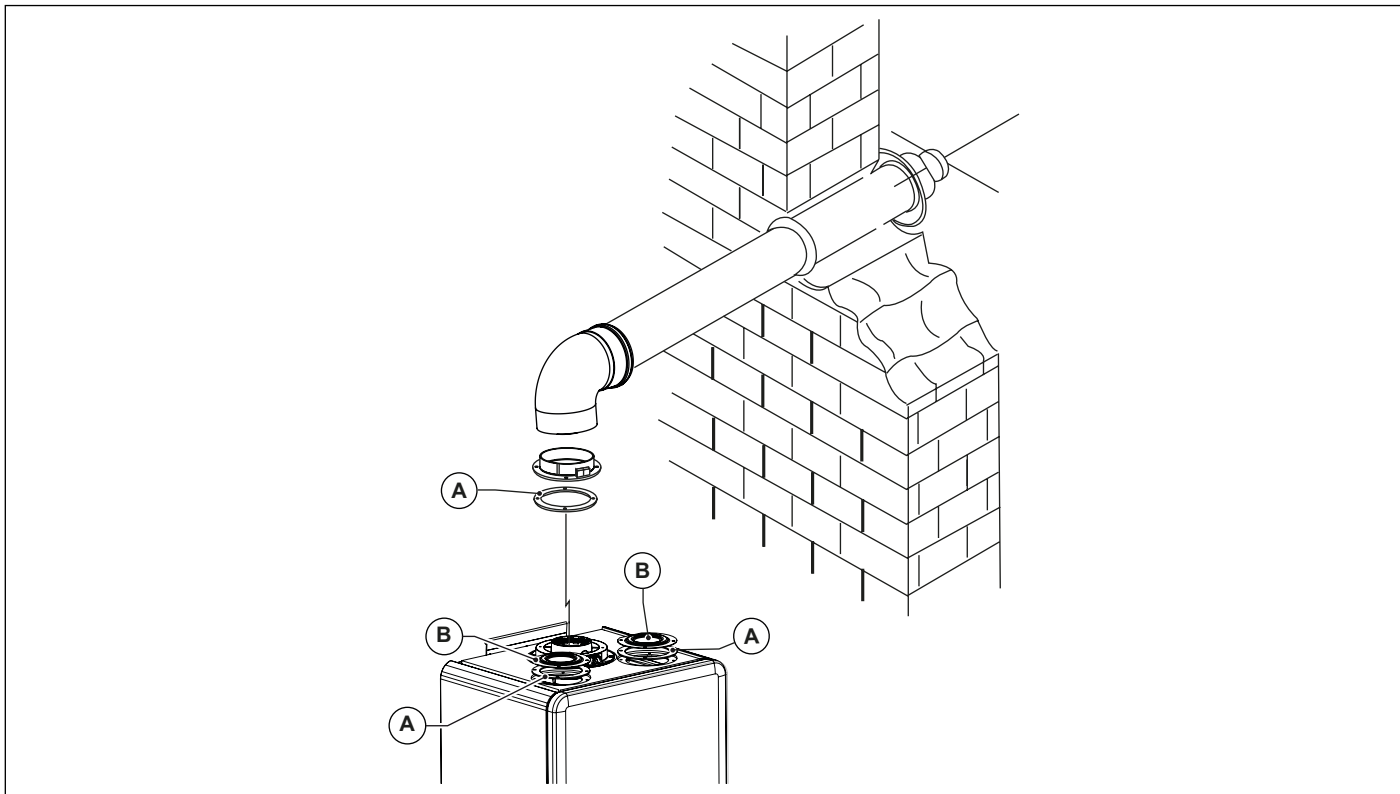

Fig. 17 Type C13 - C33 coaxial ducts

- A. Gasket
- B. Blanking cap

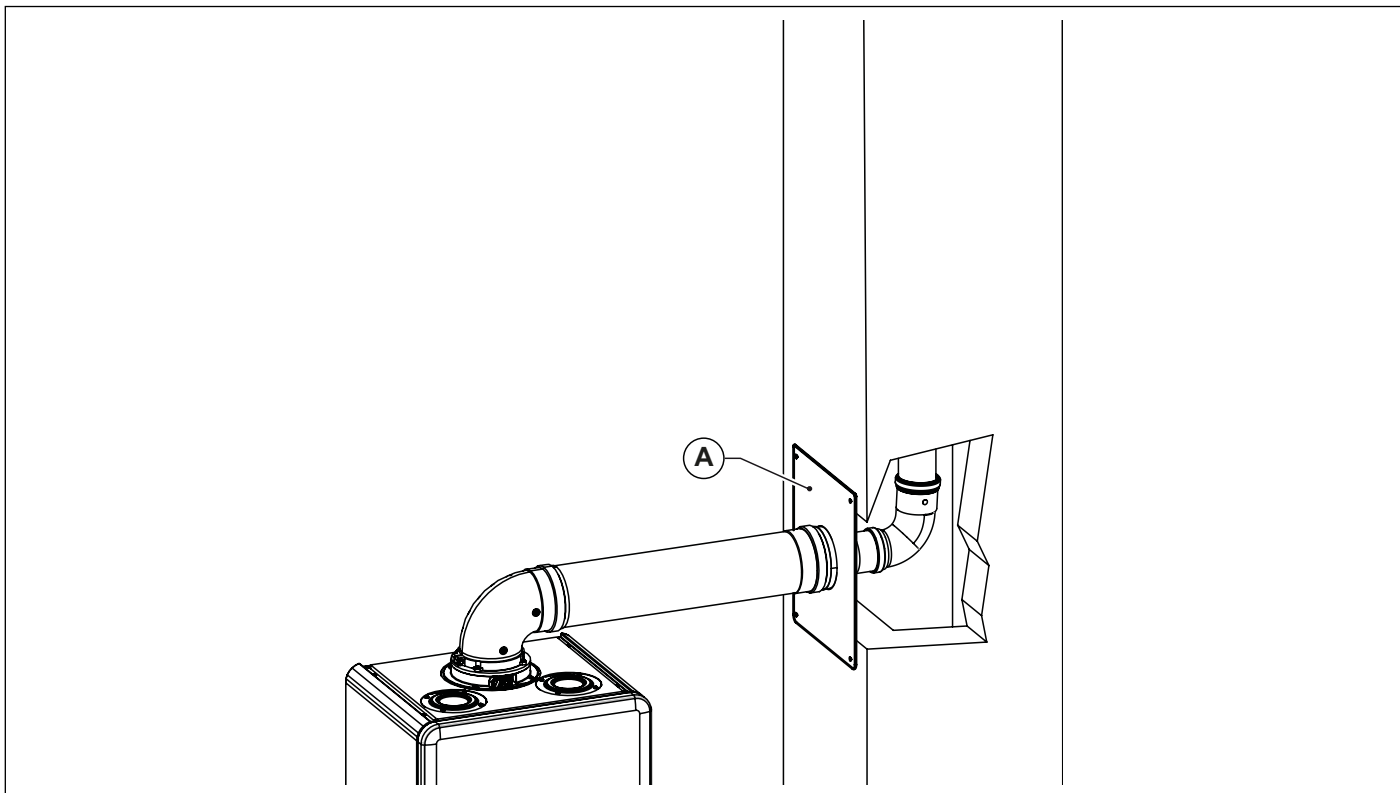

Fig. 18 Coaxial ducts C93

Ref	Accessory code (option)	Description
A	OPIASINT01	Ø 80/125 pipework plate kit
	OPIASINT02	Ø 60/100 pipework plate kit

2.8 Measuring combustion efficiency during operation

2.8.1 Flue cleaning function

The boiler features a flue cleaning function which must be used to measure combustion efficiency during operation and to adjust the burner.

To activate the flue cleaning function, it is necessary to:

- press the menu key (☰);
- turn the encoder to select the flue cleaning symbol (🔧);
- press the encoder to enter the flue cleaning function.

The flow temperature and the symbol (🔧) are shown on the LCD.

By acting on the encoder, the fan speed can be varied from a minimum to a maximum value.

To exit the flue cleaning mode, press key (↶) or wait 15 minutes.

2.8.2 Measurement procedure

The boiler is equipped with a tower allowing for air intake/flue gas venting pipe connection (see Fig. 19 Caps position and Fig. 20 Hole position).

The tower is designed with two pre-arranged openings directly accessing air and flue gas ducts (see Fig. 20 Hole position).

Remove caps **A** and **B** from the pre-arranged openings on the tower, before taking the measurements (see. Fig. 19 Caps position).

In order to verify combustion efficiency the following measurements must be implemented:

- assess combustion air from opening **1** (see Fig. 20 Hole position).
- assess flue gas and CO₂ temperature from opening **2** (see Fig. 20 Hole position).

Allow boiler to reach working temperature before taking any measurement.

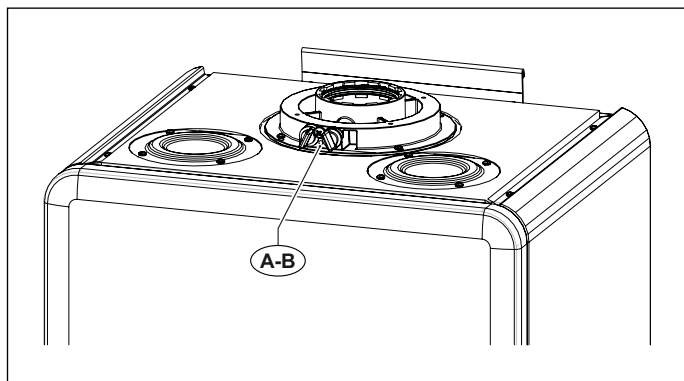

Fig. 19 Caps position

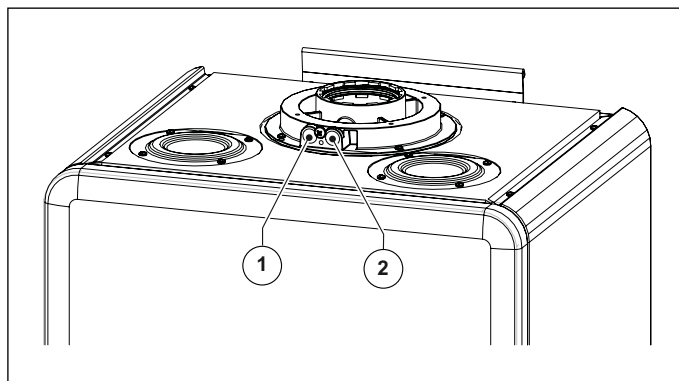

Fig. 20 Hole position

2.9 Connection to gas mains

Gas pipe cross-section must be chosen depending on its length, layout pattern, gas flow rate.
Gas supply pipe cross-section must be equal or greater than boiler pipe.



DANGER

Comply with installation standards enforced in the country where the boiler is installed which are considered as fully transcribed in this booklet.

Remember that before operating an indoor gas distribution system and before connecting it to a meter, it must be checked for leaks.

If some system parts are not visible, the leak test is to be carried out before the pipes are covered.

Leak test is **NOT** to be carried out employing flammable gas: use air or nitrogen for this purpose.

Once gas is in the pipes, leak test by a naked flame is forbidden; use specific products available on the market.

When connecting the boiler to gas supply network, it is **COMPULSORY** to install an appropriately sized gasket (A) made from suitable material (see Fig. 21 Connection to gas mains).

The boiler gas inlet coupling is **NOT** suitable for hemp, teflon tape or similarly made gaskets.

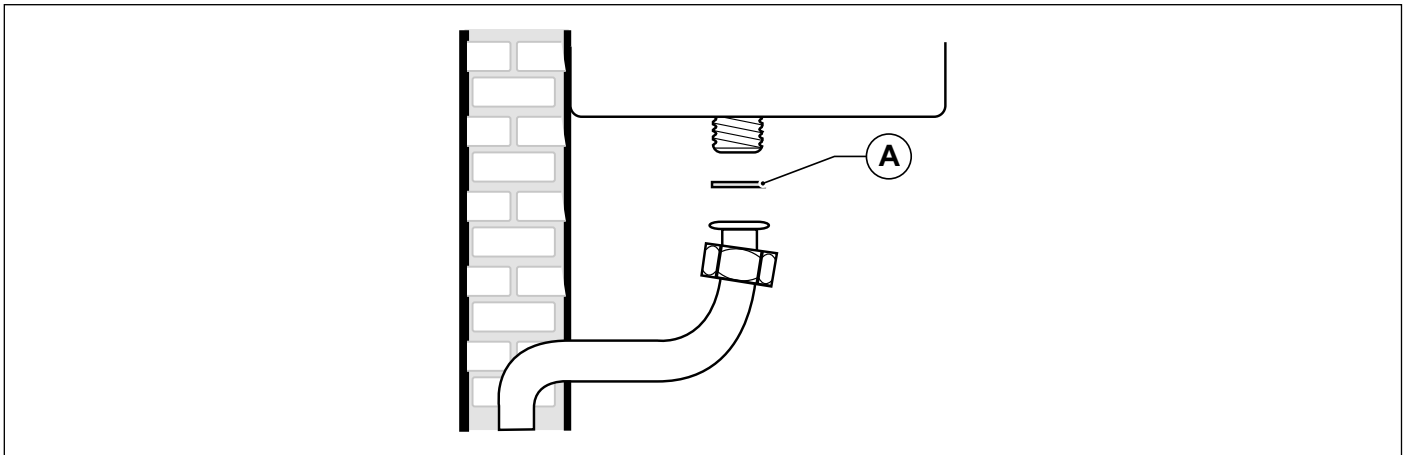

Fig. 21 Connection to gas mains

2.10 Hydraulic connections

2.10.1 Heating

Prior to installing the boiler, the hydraulic system is to be cleaned in order to remove impurities; they could be present in system components and damage the pump and the heat exchanger.

The CH outlet and return pipes must be connected to the respective 3/4" connectors **M** and **R** on the boiler (see Fig. 7 Paper template).

When calculating the cross section of CH system pipes, bear in mind load losses induced by radiators, thermostatic valves, radiator gate valves, and the configuration of the system itself.



WARNING

It is advisable to convey the discharge flow of boiler safety valve to the sewer system. Should the above precaution not be implemented and the safety valve be activated, boiler room flooding may occur.

The manufacturer shall not be held responsible in case of damage to people, animals, or property due to failure to follow the above mentioned instructions.

2.10.2 DHW

Prior to installing the boiler, the hydraulic system is to be cleaned in order to remove impurities; they could be present in system components and damage the pump and the heat exchanger.

KC Model

Cold water inlet and DHW outlet shall be connected to the boiler through the dedicated 1/2" **F** and **C** fittings.

Hardness of water supplied to the boiler may increase the plate heat exchanger cleaning/replacement intervals.

Model KR

Cold water inlet shall be connected to the boiler through the special 1/2" fitting **F**.

Model KRB

Return from the water heater (RB) and flow to water heater (MB) must be connected to the respective 1/2" connectors **F** and **C** on the boiler



WARNING

Depending on the hardness of the mains water supply, ascertain whether or not to install appropriate domestic water treatment systems using water treatment products suitable for drinking water and compliant with the regulations and standards in force in the country of installation.

Water treatment is always advisable when water supplied to the boiler has a hardness that is more than 15°f.

Water supplied by commonly marketed water softeners could, due to the chemical and physical characteristics that it takes, not be compatible with some heating system components as the loading of the system is done with DHW system water.

For this reason it is better to use polyphosphate feeders.

2.10.3 Condensate drain

Comply with condensate drain laws and standards applicable in the country of installation, which are considered herein integrally transcribed.

Unless forbidden, the condensate produced by combustion is to be routed via the condensate drain through a discharge system connected to the domestic sewer, which due to its basicity, counteracts flue gas condensate acidity. In order to avoid domestic sewer odour to reach the premises, it is advisable to install an appropriate device between the discharge system and the domestic sewer. The condensate drain system and the domestic discharge system is to be made of an adequate, condensate-resistant material.

Condensate drain system must be connected to specific fitting (A) in the boiler (see Fig. 22 Condensate drain).



WARNING

The manufacturer shall not be held responsible in case of damage to people, animals, or property due to failure to follow the above mentioned instructions.

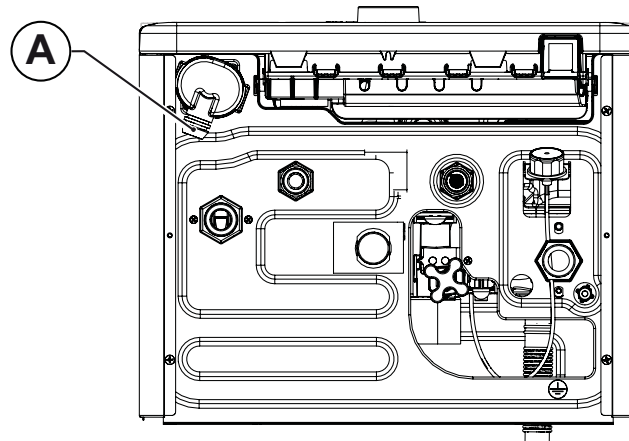

Fig. 22 Condensate drain

2.11 Connection to electrical mains

The boiler is supplied with a three-pole power cable, already connected to the electronic board and it is provided with a safety clamp. The boiler is to be connected to a 230V-50Hz electrical power supply.

When connecting it to power mains, follow correct phase / neutral polarity sequence.

Installation standards must be complied with and they are herein considered as entirely transcribed.

An easily accessible switch with contact separation in all poles must be installed upstream of boiler, directly connected to the power supply terminals to allow complete disconnection under overvoltage category III conditions and to ensure fully safe maintenance operations.

Power supply to the boiler must be fitted with a residual-current circuit breaker having suitable disconnection capacity. Power supply mains must be properly earthed.

The above mentioned safety measure must be verified. If in doubt, ask a qualified technician to thoroughly check the power network.



WARNING

The manufacturer cannot be held responsible for any damage caused by failure to earth the system correctly: gas, water, or CH system pipes are not suitable for grounding power networks.

2.12 Connection to ambient thermostat (optional)

The boiler is designed to be connected to an ambient thermostat (optional, not compulsory).

Ambient thermostat contacts must be properly sized in compliance with a load of 5 mA at 24 Vdc.

The ambient thermostat cables must be connected to terminals (1) and (2) of the electronic board (see *Wiring diagrams* on page 59) after eliminating the jumper supplied as a standard with the boiler.

The ambient thermostat cables are not to be grouped together in the same sheath as power mains supply cables.

2.13 Ambient probe installation (optional)

Boiler can be connected to a probe measuring the ambient temperature (optional not compulsory, supplied by the manufacturer).



WARNING

Only original ambient temperature probes supplied by the manufacturer must be used.

If non-original ambient temperature probes are used, correct operation of the boiler and ambient probe cannot be guaranteed.

The ambient temperature probe must be connected by means of a double insulated wire, minimum cross-section of 0.35 mm².

The ambient probe must be connected to terminals (1) and (2) of boiler electronic board.



WARNING

The ambient temperature probe cables must NOT be routed together with power cables.

If an ambient probe is installed, **P61** parameter must be set to 20.

To install the ambient probe refer to the instructions attached to the probe.

The ambient probe must be installed on an indoor wall at a height of approximately 1.5 m from the floor and in a suitable location for measuring ambient temperature: do not install in recess or corners, behind doors or curtains, and install away from heat sources, direct sunlight, air draughts and water sprays.

The ambient probe automatically modifies the CH flow temperature in relation to:

- Selected ambient temperature.
- Ambient temperature if parameter P39 = 1.
- External temperature if parameter P39 = 2.
- Ambient and external temperatures if parameter P39 = 3.

The ambient temperature is set using the encoder (key B) that, with ambient probe installed, no longer works to set the heating water temperature (see paragraph Operation with ambient probe in USER MANUAL).

The ambient temperature value detected by the ambient probe can be displayed via parameter P210 in the INFO menu (see section INFO MENU in USER MANUAL).

2.14 Installation and operation with Open Therm Remote Control (optional)



WARNING

Only use original Remote Controls supplied by the manufacturer.

The correct operation of the Remote Control itself and of the boiler is not guaranteed if non-original Remote Controls not supplied by the manufacturer are used.

The boiler may be connected to an Open Therm Remote Control (non-compulsory optional accessory supplied by manufacturer).

The Remote Control must only be installed by qualified personnel.

To install the Remote Control, refer to the instructions provided with the Remote Control itself.

The Remote Control must be installed on an indoor wall at a height of approximately 1.5 m from the floor and in a suitable location for measuring ambient temperature: do not install in recess or corners, behind doors or curtains, and install away from heat sources, direct sunlight, air draughts and water sprays.

The Remote Control cables must be connected to terminals 3 and 4 of the electronic board.

The Remote Control connector is protected against inverted polarity, and the connections may be inverted.



WARNING

Do not connect the remote control to mains electrical power 230 V ~ 50 Hz.

The remote control wiring must not be grouped together in the same sheath as the power cables: if the cables are sheathed together, electrical interference from the power cables may compromise the functions of the Remote Control;



WARNING

When connecting the Remote Control to terminals 3 and 4, set parameter P61 to 0 or 2 (see paragraph *TSP parameters* on page 49).

For complete instructions on how to program the Remote Control, refer to the instruction manual included in the Remote Control kit.

Board and Remote Control communicate in each operating mode: OFF, SUMMER, WINTER, CH ONLY.

Boiler display layout corresponds to the setting made from the Remote Control, as for the operating mode.

The remote control may be used to view and set a number of special parameters denominated **TSP** parameters and reserved solely for qualified technicians.



Setting the **TSP0** parameter sets the default data table and reloads all original data, cancelling any modifications previously made to individual parameters.

If a single parameter is found to be incorrect, the value given in the default value table is restored.

If the user attempts to set a value not within the permissible range for the parameter, the new value is rejected and the existing value is maintained.

2.15 Selecting the operating range in heating mode

To set the water temperature for central heating, proceed as follows:

- turn the encoder (key B), the area where the heating symbol  is located turns grey;
- press the encoder;
- turn the encoder clockwise or anticlockwise to increase or decrease the central heating setpoint temperature;
- press the encoder to confirm set value;
- press key  to quit the setpoint setting.

Heating water temperature adjustment range depends on the selected operating range.:

- standard range: from 20 °C to 78 °C (using the encoder as shown above);
- reduced range: from 20 °C to 45 °C (using the encoder as shown above).

The standard range is active with parameters **P62, P64 and P66** ≥ 100 , while the reduced range is active with parameters **P62, P64 and P66** < 100 .

The two ranges can also be selected even with the external probe disconnected.

The waiting time between one boiler ignition and the following one, used to prevent boiler frequent turning on and off during CH operation is 4 minutes for both ranges, and can be edited with the parameter **P11**.

If system water temperature decreases below a certain value, the waiting time is reset and the boiler re-ignited, as shown in the following table:

Selected range	Re-ignition temperature
Standard range	$< 30^{\circ}\text{C}$ (P27)
Reduced range	$< 20^{\circ}\text{C}$

Tab. 24 Burner re-ignition temperature

Operation range selection is to be implemented by a qualified installer or a Service Centre.

2.16 Installation of the (optional) external probe and sliding temperature operation

The boiler can be connected to an external temperature probe (optional, provided by the manufacturer) for sliding temperature operation.



WARNING

Only original external temperature probes supplied by the manufacturer must be used.

If non-original external temperature probes are used, correct operation of the boiler and external probe cannot be guaranteed.

The external temperature probe must be connected by means of a double insulated wire, minimum cross-section 0.35 sq.mm. The external probe must be connected to terminals (5) and (6) of boiler electronic board.



WARNING

The temperature probe cables must NOT be routed together with power cables.

The temperature probe must be installed on an outside wall facing NORTH - NORTH EAST, in a position protected from weather. Do not install near a window, ventilation openings or sources of heat.

The external temperature probe automatically modifies the CH flow temperature in relation to:

- Measured external temperature.
- Selected thermoregulation curve.
- Selected fictitious ambient temperature.

The thermoregulation curve is selected via parameters **P62, P64 and P66**.

During adjustment, the set value will flash on LCD. Such value can also be read as parameters **TSP62, TSP64 and TSP66** on the Remote Control (when installed).

The fictitious ambient temperature is set using the encoder (key B) that, with external temperature probe installed, no longer works to set the heating water temperature (see paragraph Operation with external probe (optional) in USER MANUAL).

The external temperature value detected by the external probe can be displayed via parameter P200 in the INFO menu (see section INFO MENU in USER MANUAL).

The figure shows the curves for a fictitious ambient temperature of 20°C. Parameters **P62, P64 and P66** allow selecting the curve value shown (see Fig. 23 Thermoregulation curves).

If fictitious ambient temperature value is edited on boiler display, the curves shift up or down, respectively, by the same amount.

With a fictitious ambient temperature setting of 20°C, for example, if you select the curve corresponding to parameter 1 and the outdoor temperature is -4°C, the CH flow temperature will be 50°C.

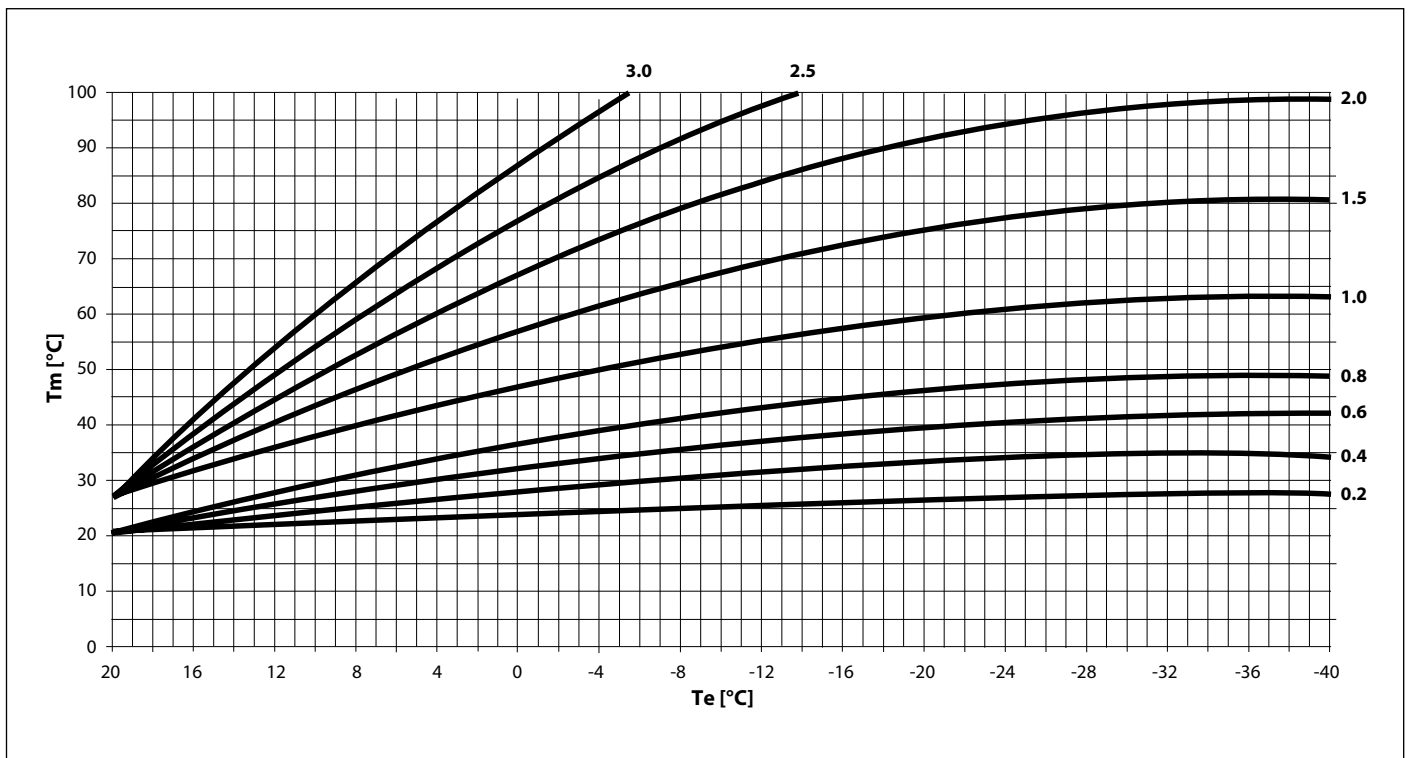





Fig. 23 Thermoregulation curves

Tm indicates flow water temperature in °C

Te indicates external temperature in °C

2.17 TSP parameters

- press the **menu** (☰) key for 10 seconds;
- turn the encoder (key B), the area where the heating symbol  is located turns grey;
- press the encoder;
- turn the encoder clockwise or anticlockwise to scroll the parameter list. As soon as you reach the one to be edited, press the encoder;
- turn the encoder, the symbol  turns grey.
- press the encoder;
- turn the encoder clockwise or anticlockwise to increase or decrease the value of the parameter to be edited;
- press the encoder to confirm set value;
- press key  until the display returns to the main page.

The boiler operation is controlled by several parameters.

To modify the parameters, proceed as follows:

Parameter	Settable values	Default values	Notes
P0 - TSP0 Boiler output selection	0 ÷ 7	According to the model	0 = 12 kW - 18 kW natural gas 1 = 24 kW - 26 kW natural gas 2 = 28 kW - 30 kW natural gas 3 = 24 kW - 26 kW propane 4 = 28 kW - 30 kW propane 5 = 12 kW - 18 kW propane 6 = 32 kW - 35 kW natural gas 7 = 32 kW - 35 kW propane
P3 - TSP3 Boiler type selection	1 ÷ 3	According to the model	1 = combined instantaneous 2 = heating only 3 = with water heater
P4 - TSP4 (*) Fan speed at burner maximum output	P5 ÷ 10,000 rpm	According to the model	12 kW - 18 kW natural gas = 8,850 12 kW - 18 kW propane = 8,900 24 kW - 26 kW natural gas = 8800 24 kW - 26 kW propane = 8600 28 kW - 30 kW natural gas = 8900 28 kW - 30 kW propane = 8800 32 kW - 35 kW natural gas = 8800 32 kW - 35 kW propane = 8600
P5 - TSP5 (*) Fan speed at burner minimum output	750 ÷ 7650 rpm	According to the model	12 kW - 18 kW natural gas = 1310 12 kW - 18 kW propane = 1390 24 kW - 26 kW = 1350 28 kW - 30 kW natural gas = 1390 28 kW - 30 kW propane = 1370 32 kW - 35 kW natural gas = 1510 32 kW - 35 kW propane = 1500
P6 - TSP6 (*) Fan speed at ignition power	750 ÷ 7650 rpm	According to the model	12 kW - 18 kW natural gas = 4000 12 kW - 18 kW propane = 2700 24 kW - 26 kW = 4000 28 kW - 30 kW = 4000 32 kW - 35 kW = 4000

Tab. 25 Limits to be set for TSP parameters and default values in relation to boiler type (TSP0) - I

(*) password-protected parameter

Parameter	Settable values	Default values	Notes
P7 - TSP7 Fan speed at heating maximum output	10 ÷ 100%	According to the model	12 kW - 18 kW = 69 24 kW - 26 kW = 88 28 kW - 30 kW = 89 32 kW - 35 kW = 89
P10 - TSP10 (*) Setpoint ΔT between flow and return lines	0 ÷ 50 °K	20 °K	-
P11 - TSP11 Heating thermostat timer	0 ÷ 10 min.	4	-
P12 - TSP12 CH output rising ramp timer	0 ÷ 10 min.	4	-
P13 - TSP13 Timer for CH post-circulation, freeze protection and flue cleaning function	0.5 ÷ 30 min.	0.5 min.	-
P15 - TSP15 Water hammer protection delay, configurable	0 ÷ 10 sec.	0	-
P16 - TSP16 Boiler switch-on delay from ambient thermostat/remote control/room probes	0 ÷ 199 sec.	0 sec.	-
P17 - TSP17 Multifunction relay setting	0, 1, 3, 4, 7	0	0 = shut-down and fault 1 = ambient thermostat 1/Remote Control request 3 = ambient thermostat 2 request 4 = LPG valve 7 = request from at least one heating zone
P18 - TSP18 Multifunction 3-way relay setting	0 ÷ 8	0	0 = shut-down and fault 1 = external 3-way line for water heater 2 = solar-1 (valve) 3 = solar-2 (boiler filling) 4 = LPG valve 5 = circuit breaker pump for filling with water heater 6 = water heater recirculation pump 7 = not available 8 = return temperature increase
P27 - TSP27 Heating timer reset temperature	20 ÷ 78 °C	30 °C	-
P29 - TSP29 Setting of default parameters (except P0, P17, P18, P126)	0 ÷ 1	0	0 = user's parameters 1 = default parameters
P30 - TSP30 Triggering temperature differential OFF can be set via parameter for zone 1	0.0 ÷ 1.0 °C	0 °C	only with connected ambient probes
P31 - TSP31 Triggering temperature differential ON can be set via parameter for zone 1	0.1 ÷ 1.0 °C	0.5 °C	only with connected ambient probes
P32 - TSP32 Ambient temperature probe correction range that can be set via parameter for zone 1	-5.0 ÷ +5.0 °C	0 °C	-
P33 - TSP33 Triggering temperature differential OFF can be set via parameter for zone 2	0.0 ÷ 1.0 °C	0 °C	only with connected ambient probes and zone board
P34 - TSP34 Triggering temperature differential ON can be set via parameter for zone 2	0.1 ÷ 1.0 °C	0.5 °C	only with connected ambient probes and zone board

Tab. 26 Limits to be set for TSP parameters and default values in relation to boiler type (TSP0) - II

(*) password-protected parameter

Parameter	Settable values	Default values	Notes
P35 - TSP35 Ambient temperature probe correction range that can be set via parameter for zone 2	-5.0 ÷ +5.0 °C	0 °C	-
P36 - TSP36 Triggering temperature differential OFF can be set via parameter for zone 3	0.0 ÷ 1.0 °C	0 °C	only with connected ambient probes and zone board
P37 - TSP37 Triggering temperature differential ON can be set via parameter for zone 3	0.1 ÷ 1.0 °C	0.5 °C	only with connected ambient probes and zone board
P38 - TSP38 Ambient temperature probe correction range that can be set via parameter for zone 3	-5.0 ÷ +5.0 °C	0 °C	-
P39 - TSP39 Ambient modulation type	0, 1, 3	1	only with connected ambient probes 1 = ambient probe modulation 2 = external probe modulation 3 = ambient and external probe modulation
P40 - TSP40 Ambient temperature influence	0 ÷ 20	8	-
P42 - TSP42 Parameter Tmin for modulating flow set on ambient for curves<1	0 ÷ 78 °C	30 °C	-
P43 - TSP43 Multiplication parameter for modulating set on ambient	0 ÷ 78	20	-
P44 - TSP44 Minimum limit for STANDARD range of CH temperature (CURVES≥1)	20 ÷ 59 °C	35 °C	-
P45 - TSP45 Maximum limit for STANDARD range of CH temperature (CURVES≥1)	60 ÷ 78 °C	78 °C	-
P46 - TSP46 Minimum limit for REDUCED range of CH temperature (CURVES<1)	20 ÷ 30 °C	20 °C	-
P47 - TSP47 Maximum limit for REDUCED range of CH temperature (CURVES<1)	31 ÷ 45 °C	45 °C	-
P48 - TSP48 Hysteresis OFF CH thermostat off curves P62-64-66 ≥1	1 ÷ 5 °K	5 K	-
P49 - TSP49 Hysteresis ON CH thermostat off curves P62-64-66 ≥1	-5 ÷ +0 °C	0 °C	-
P50 - TSP50 Hysteresis OFF CH thermostat off curves P62-64-66<1	1 ÷ 5 °K	2 K	-
P51 - TSP51 Hysteresis ON CH thermostat off curves P62-64-66<1	-5 ÷ +0 °C	0 °C	-
P52 - TSP52 Water heater filling hysteresis	1 ÷ 20 °K	3 K	-

Tab. 27 Limits to be set for TSP parameters and default values in relation to boiler type (TSP0) - III

Parameter	Settable values	Default values	Notes
P57 - TSP57 Frost protection start temperature for ambient/external probes	0 ÷ 15 °C	5 °C	only if P306 = 1
P58 - TSP58 Frost protection end temperature for ambient/external probes	0 ÷ 15 °C	6 °C	only if P306 = 1
P60 - TSP60 Number of additional boards connected	0 ÷ 3	0	-
P61 - TSP61 Type of system	0 ÷ 20	7	0 = remote zone 2 / TA2 zone 1 1 = TA1 zone 1 / TA2 zone 2 2 = TA2 zone 2 / remote zone 1 3 = SA zone 1 / TA1 zone 2 4 = SA zone 1 / SA2 zone 2 5 = remote zone 1 / SA2 zone 2 6 = zone 1 not managed / SA2 zone 2 7 = TA1 zone 1 / zone 2 not managed 8 = remote zone 2 / TA2 zone 1 / TA3 zone 3 9 = zone 1 not managed / remote zone 2 / TA3 zone 3 10 = remote zone 1 / SA2 zone 2 / SA3 zone 3 11 = SA2 zone 1 / remote zone 2 12 = SA2 zone 1 / remote zone 2 / SA3 zone 3 13 = SA zone 1 / SA2 zone 2 / SA3 zone 3 14 = TA1 zone 1 / TA2 zone 2 / TA3 zone 3 15 = zone 1 not managed / TA2 zone 2 16 = zone 1 not managed / TA2 zone 2 / TA3 zone 3 17 = zone 1 not managed / SA2 zone 2 / SA3 zone 3 18 = zone 1 not managed / remote zone 2 19 = remote zone 1 / TA2 zone 2 / TA3 zone 3 20 = SA zone 1 / zone 2 not managed
P62 - TSP62 Selection of zone 1 curve	0 ÷ 300	150	-
P63 - TSP63 Zone 1 set-point	5 ÷ 30 °C	20 °C	can be selected from home page on the display only with external probe/ambient probe required ambient temperature setpoint
	20 ÷ 78 °C (P62>=1)	60 °C	can be selected from home page on the display radiator temperature setpoint with no external probe and no ambient probe
	20 ÷ 45 °C (P62<1)	35 °C	can be selected from home page on the display radiator temperature setpoint with no external probe and no ambient probe

Tab. 28 Limits to be set for TSP parameters and default values in relation to boiler type (TSP0) - IV

Parameter	Settable values	Default values	Notes
P64 - TSP64 Selection of zone 2 curve	0 ÷ 300	150	-
P65 - TSP65 Zone 2 set-point	5 ÷ 30 °C	20 °C	can be selected from home page on the display only with external probe/ambient probe required ambient temperature setpoint
	20 ÷ 78 °C (P64>=1)	60 °C	can be selected from home page on the display radiator temperature setpoint with no external probe and no ambient probe
	20 ÷ 45 °C (P64<1)	35 °C	can be selected from home page on the display radiator temperature setpoint with no external probe and no ambient probe
P66 - TSP66 Selection of zone 3 curve	0 ÷ 300	150	only with zone board connected
P67 - TSP67 Zone 3 set-point	5 ÷ 30 °C	20 °C	can be selected from home page on the display only with external probe/ambient probe required ambient temperature setpoint
	20 ÷ 78 °C (P66>=1)	60 °C	can be selected from home page on the display radiator temperature setpoint with no external probe and no ambient probe
	20 ÷ 45 °C (P66<1)	35 °C	can be selected from home page on the display radiator temperature setpoint with no external probe and no ambient probe
P70 - TSP70 (*) Inhibition range when setpoint is reached: positive limit	0 ÷ 3 °K	1.5 K	only with zone board connected
P71 - TSP71 (*) Inhibition range when setpoint is reached: negative limit	0 ÷ 3 °K	2 K	only with zone board connected
P72 - TSP72 (*) Proportional factor KP PID of mixed zones	0 ÷ 255	3	-
P73 - TSP73 (*) Integrative factor KI PID of mixed zones	0 ÷ 255	4	-
P74 - TSP74 (*) Derivative factor KD PID of mixed zones	0 ÷ 255	10	-
P77 - TSP77 External probe	0 ÷ 1	0	0 = no external probe 1 = external probe present
P80 - TSP80 Multifunction relay forcing	0 ÷ 2	0	0 = standard function 1 = relay energised 2 = relay not energised
P81 - TSP81 Zone 2 pump relay forcing	0 ÷ 2	0	0 = standard function 1 = relay energised 2 = relay not energised
P82 - TSP82 Zone 2 mixing valve forcing	0 ÷ 4	0	0 = standard function 1 = force opening 2 = force closing 3 = all relays not energised 4 = all relays energised

Tab. 29 Limits to be set for TSP parameters and default values in relation to boiler type (TSP0) - V

(*) password-protected parameter

Parameter	Settable values	Default values	Notes
P84 - TSP84 Zone 3 pump relay forcing	0 ÷ 2	0	0 = standard function 1 = relay energised 2 = relay not energised
P85 - TSP85 Zone 3 mixing valve forcing	0 ÷ 4	0	0 = standard function 1 = force opening 2 = force closing 3 = all relays not energised 4 = all relays energised
P86 - TSP86 Multifunction relay2 forcing	0 ÷ 2	0	0 = standard function 1 = relay energised 2 = relay not energised
P87 DHW plate exchanger setpoint	35 ÷ 57 °C	-	can be selected from home page on the display only for KC models
P88 DHW water heater setpoint	35 ÷ 65 °C	-	can be selected from home page on the display for KRB models, with connected water heater probe
P89 - TSP89 Multifunction input	0 ÷ 3	0	0 = ambient thermostat (TA2) 1 = ambient probe (SA) 2 = hydraulic separator probe 3 = boiler separator probe off
P95 - TSP95 (*) Pwm for minimum modulating pump speed	0 ÷ 100%	72%	P10 parameter must also be set
P306 - TSP160 Freeze protection enabling with external probe	0 ÷ 1	0	-

Tab. 30 Limits to be set for TSP parameters and default values in relation to boiler type (TSP0) - VI

(*) password-protected parameter

2.18 Filling the system

Once all boiler connections have been completed, CH system can be filled.

The procedure is to be cautiously carried out, following each step:

- Open the bleeding valves on all radiators and verify the boiler automatic valve operation.
- Gradually open the relevant filler cock, checking that any automatic bleeding valves installed in the system properly work (see Filler cock figure in USER MANUAL).
- Close all radiator bleeding valves as soon as water starts coming out.
- Check on the boiler's pressure gauge that water pressure reaches the 1÷1.3 bar reading.
- Shut the filler cock and bleed any air out again, by opening the air bleeding valves on radiators.
- Start the boiler and bring the system to working temperature, stop the pump, and repeat air bleeding procedure.
- Allow the system to cool and restore water pressure to 1÷1.3 bars.



WARNING

The low water safety pressure switch will not electrically enable the burner ignition when water pressure is below 0.4-0.6 bar.

The CH system water pressure must not be lower than 1 bar. Otherwise, fill the heating system.

The procedure is to be followed while the system is cold.

Pressure gauge is used to read pressure inside the heating circuit.



WARNING

As for water treatment in the domestic heating systems in order to optimise efficiency and safety, ensure a long life, trouble-free operation of auxiliary equipment, minimise power consumption, thereby integrating the standards and rules in force in the country of installation, it is recommended to use specific products suitable for multi-metal heating systems.

2.19 Starting up the boiler

2.19.1 Preliminary checks

Before starting the boiler, check that:

- The flue gas venting duct and the relevant terminal are installed in conformity with the instructions: with the boiler operating, there must be no leakage of combustion by-products from any of the gaskets.
- The supply power to the boiler must be 230 V ~ 50 Hz.
- The heating system is correctly filled with water (pressure gauge reading 1÷1.3 bar).
- Any shut-off cocks in the system pipes are open.
- The mains gas type is correct for the boiler calibration: convert the boiler to the available gas if necessary (see *Adaptation to other gas types and burner adjustment* on page 66). This operation is to be exclusively carried out by qualified personnel.
- The gas supply cock is open.
- There are no fuel gas leaks.
- The main switch installed adjacent to the boiler is turned on.
- The safety valve is not blocked.
- The condensate trap installed on the boiler is discharging condensate correctly and is not stuck.

2.19.2 Switching on and switching off

To switch the boiler on and off, refer to the “**Instructions for the User**” (see paragraph Instructions for the user in USER MANUAL).

2.20 Available head

The boiler is equipped with a high-efficiency circulation pump with variable speed.

Circulation pump speed is automatically managed by the electronics, based on the settings of "super technical" parameters of the boiler.

It is possible to choose between two pump working modes:

1 "Constant ΔT " operation

In the constant ΔT operating mode, circulation pump speed changes automatically to keep system flow and return ΔT fixed at a value set in the boiler "super technical" parameters.

2 "Fixed speed" operation

In the fixed speed operating mode, circulation pump speed remains constant at the value set in the boiler "super technical" parameters.

In DHW mode circulation pump works at a fixed speed, set via the relevant "super technical" parameters of the boiler.



WARNING

Circulation pump is set to constant ΔT operating mode during production.

For a correct operation of the boiler, it is recommended not to change factory setting.

Should it be necessary to change circulation pump settings to adjust its operation to the system or to reduce noise, contact a Service Centre.

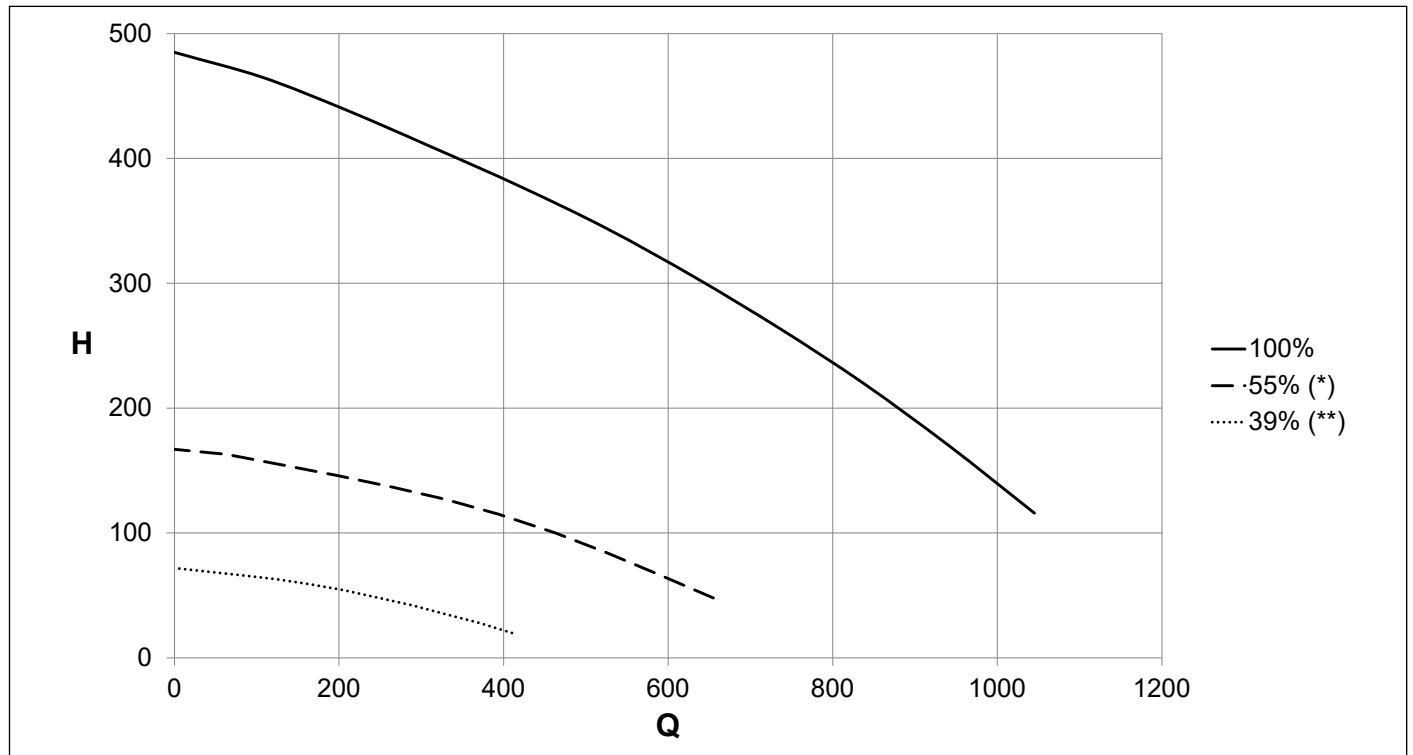

Fig. 24 Available head KC 18 - KR/KRB 12

Q Flow rate (l/h)

H Available head (mbar)

(*) Minimum curve that can be used in systems without hydraulic separator

(**) Minimum curve that can be used in systems with hydraulic separator

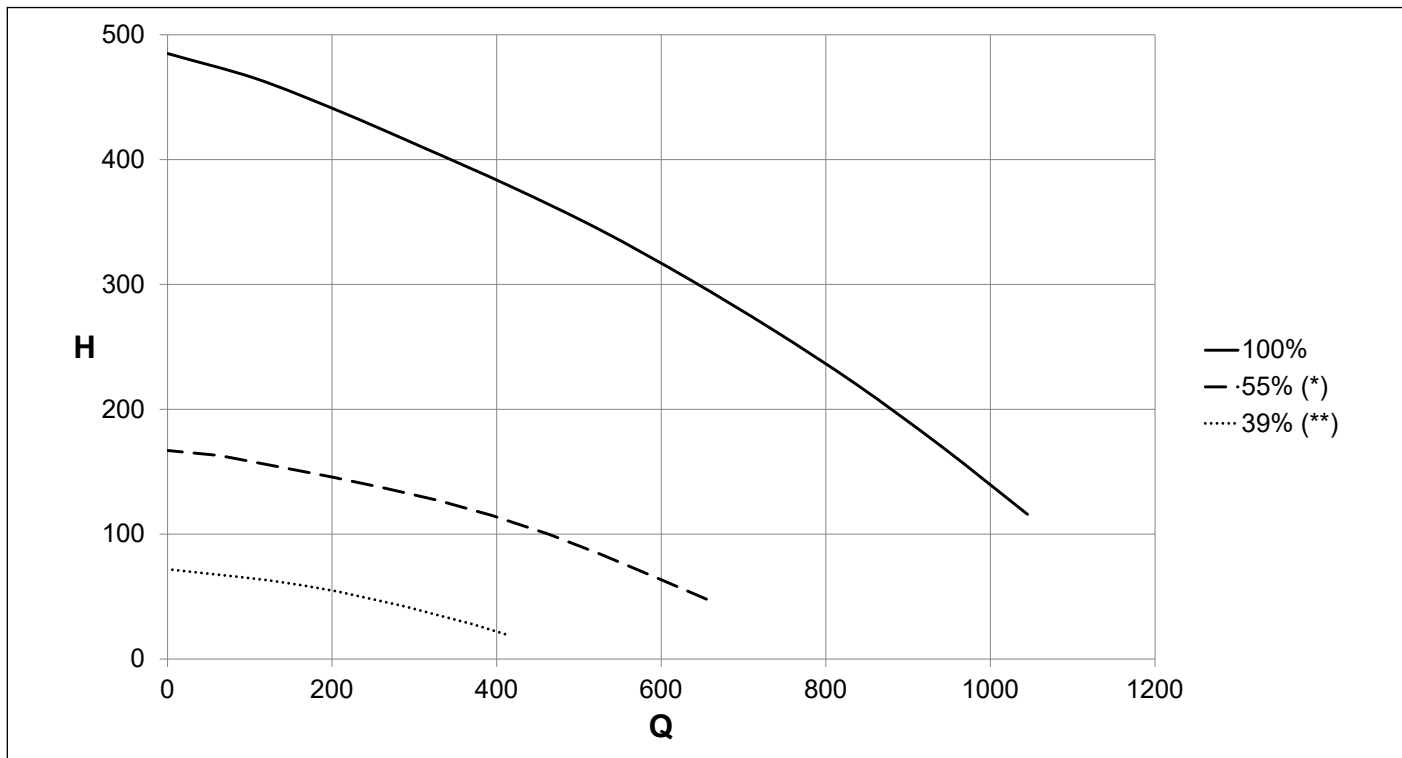

Fig. 25 Available head KC 26 - KR/KRB 24

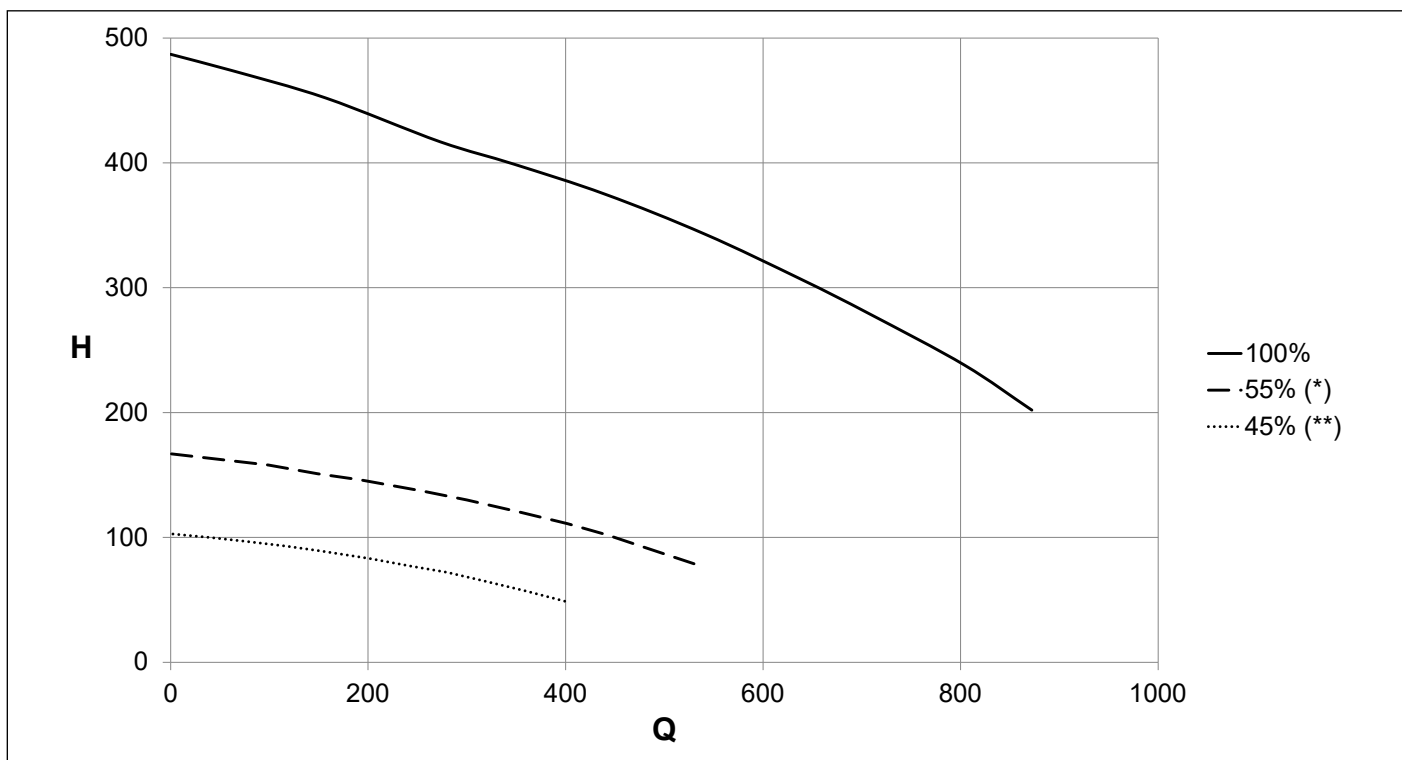

Fig. 26 Available head KC 30 - KR/KRB 28

Q Flow rate (l/h)

H Available head (mbar)

(*) Minimum curve that can be used in systems without hydraulic separator

(**) Minimum curve that can be used in systems with hydraulic separator

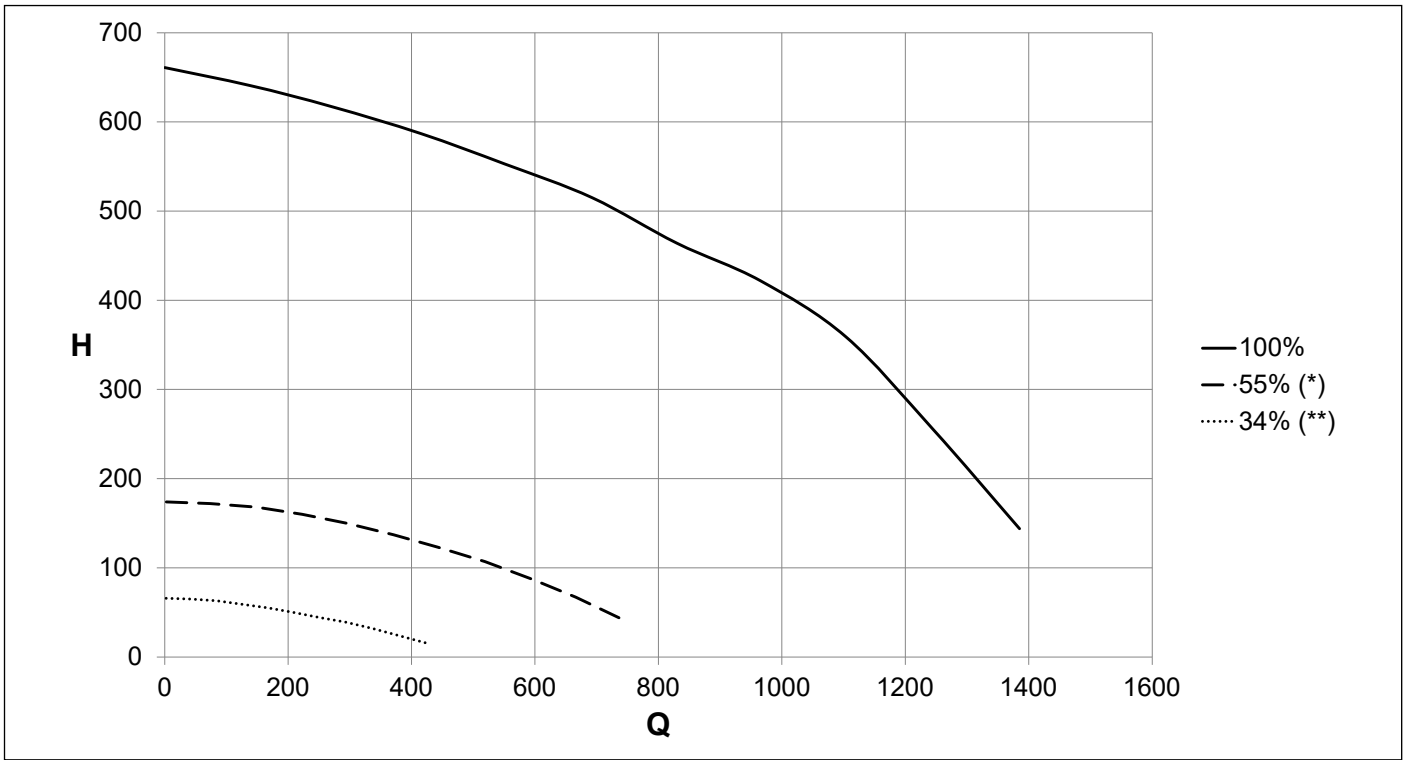

Fig. 27 Available head KC 35 - KR/KRB 32

Q Flow rate (l/h)

H Available head (mbar)

(*) Minimum curve that can be used in systems without hydraulic separator

(**) Minimum curve that can be used in systems with hydraulic separator

2.21 Wiring diagrams

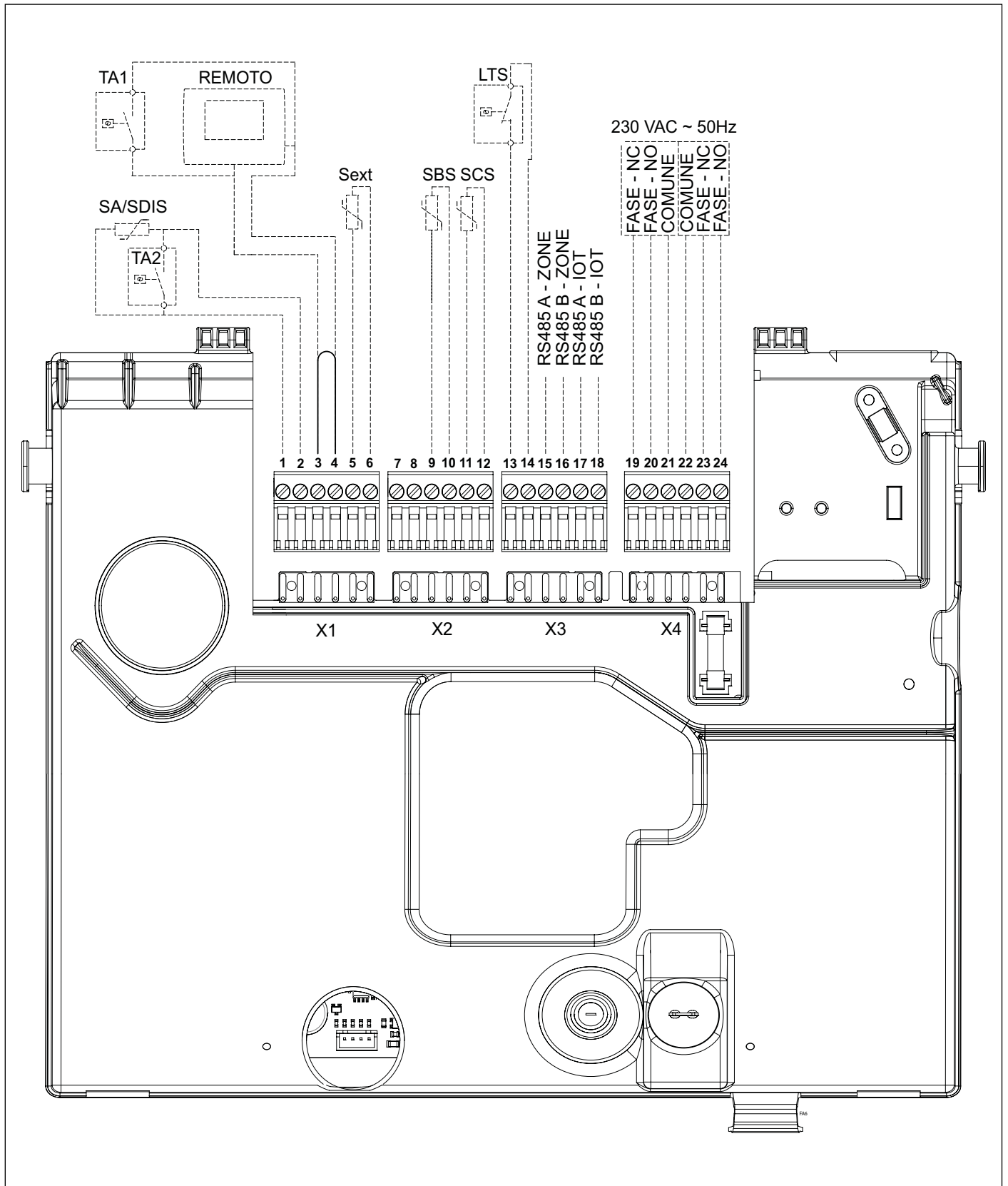

Fig. 28 Wiring diagram KC (I)



WARNING

The cables of multifunction relay (19-20-21-22-23-24) must be set inside suitable cableways, separate from any other cables (1-2-3-4-5-6-7-8-9-10-11-12-13-14-15-16-17-18).

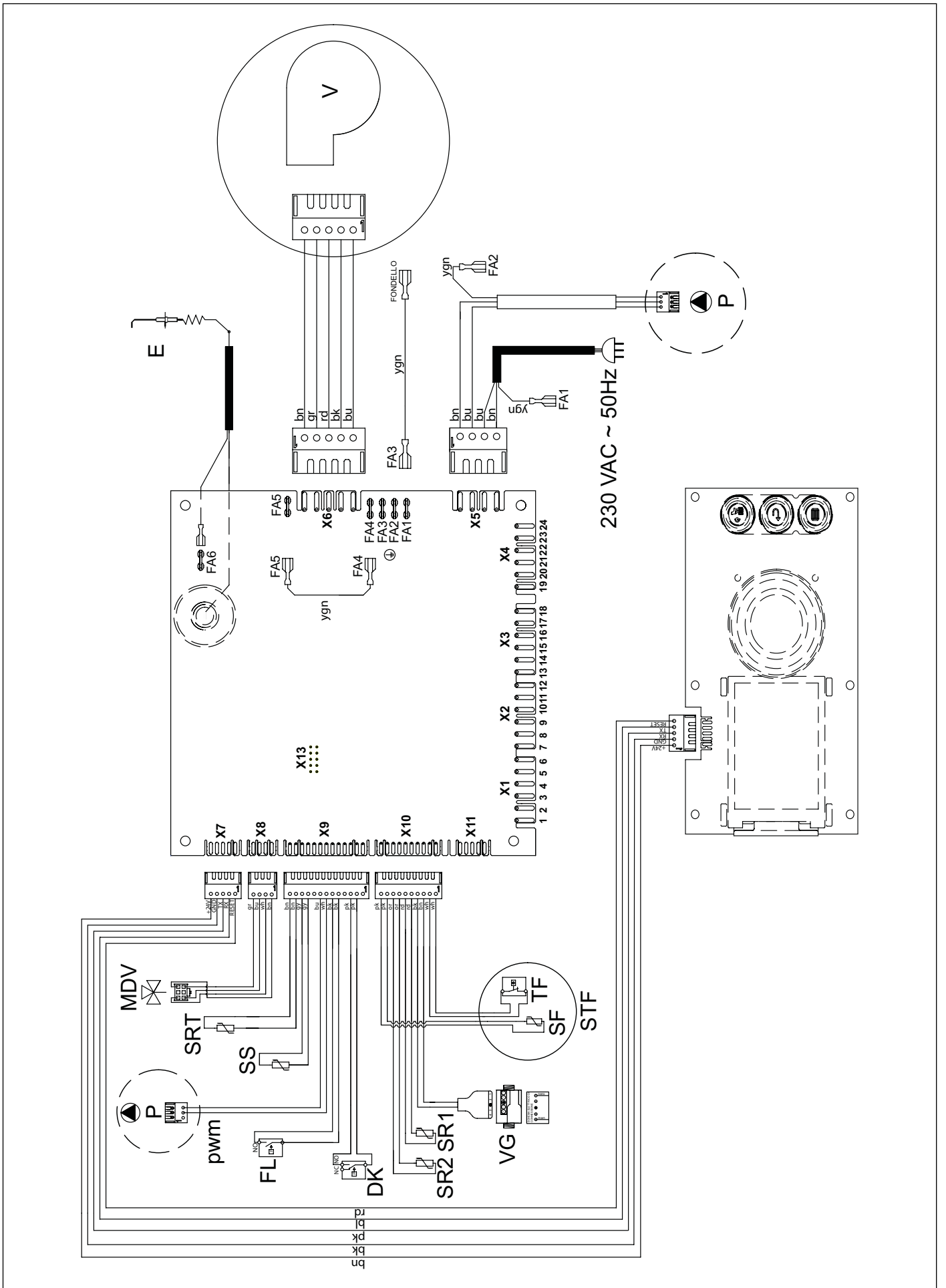

Fig. 29 Wiring diagram KC (II)

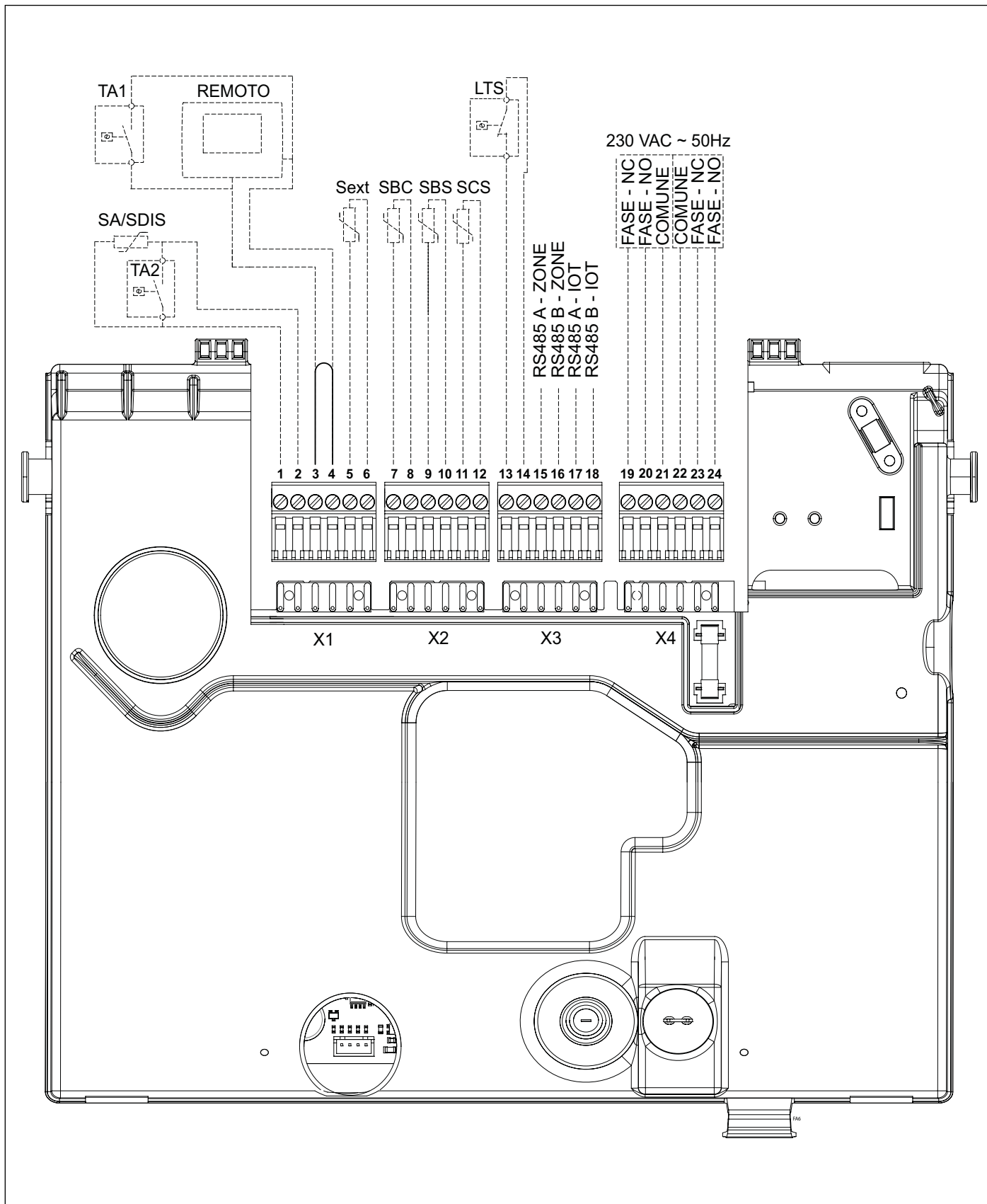

Fig. 30 Wiring diagram KR (I)



WARNING

The cables of multifunction relay (19-20-21-22-23-24) must be set inside suitable cableways, separate from any other cables (1-2-3-4-5-6-7-8-9-10-11-12-13-14-15-16-17-18).

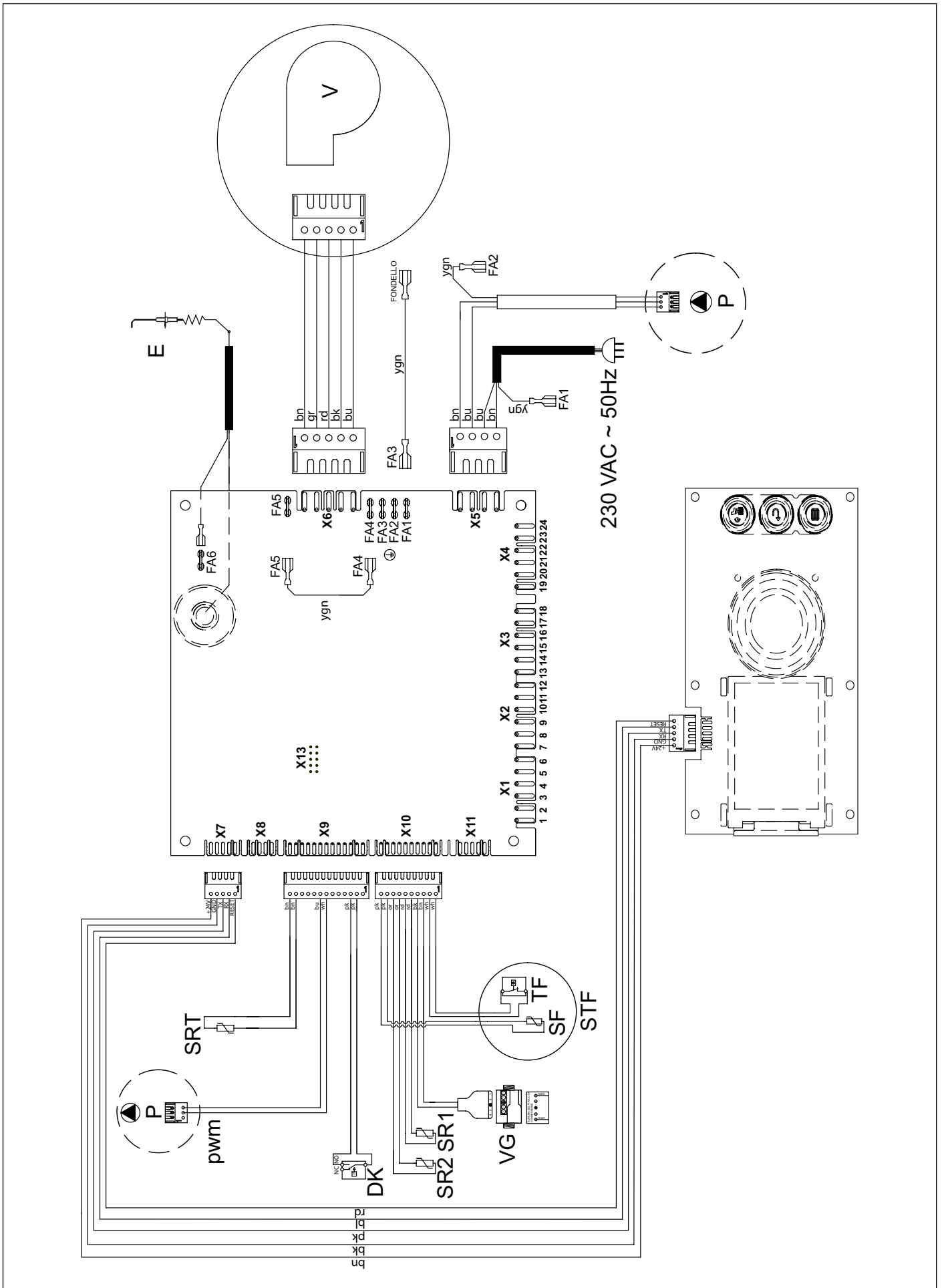

Fig. 31 Wiring diagram KR (II)

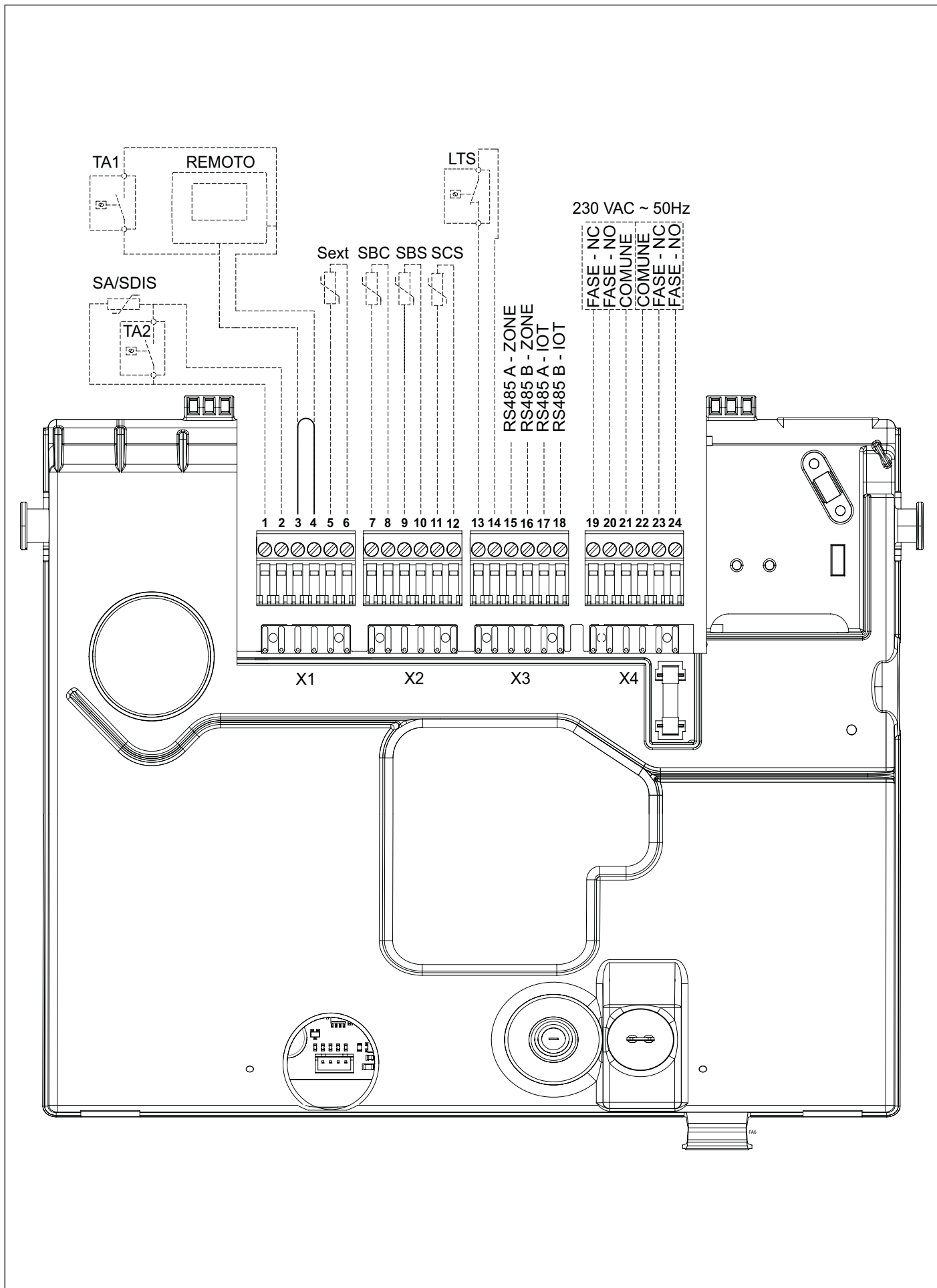

Fig. 32 Wiring diagram KRB (I)

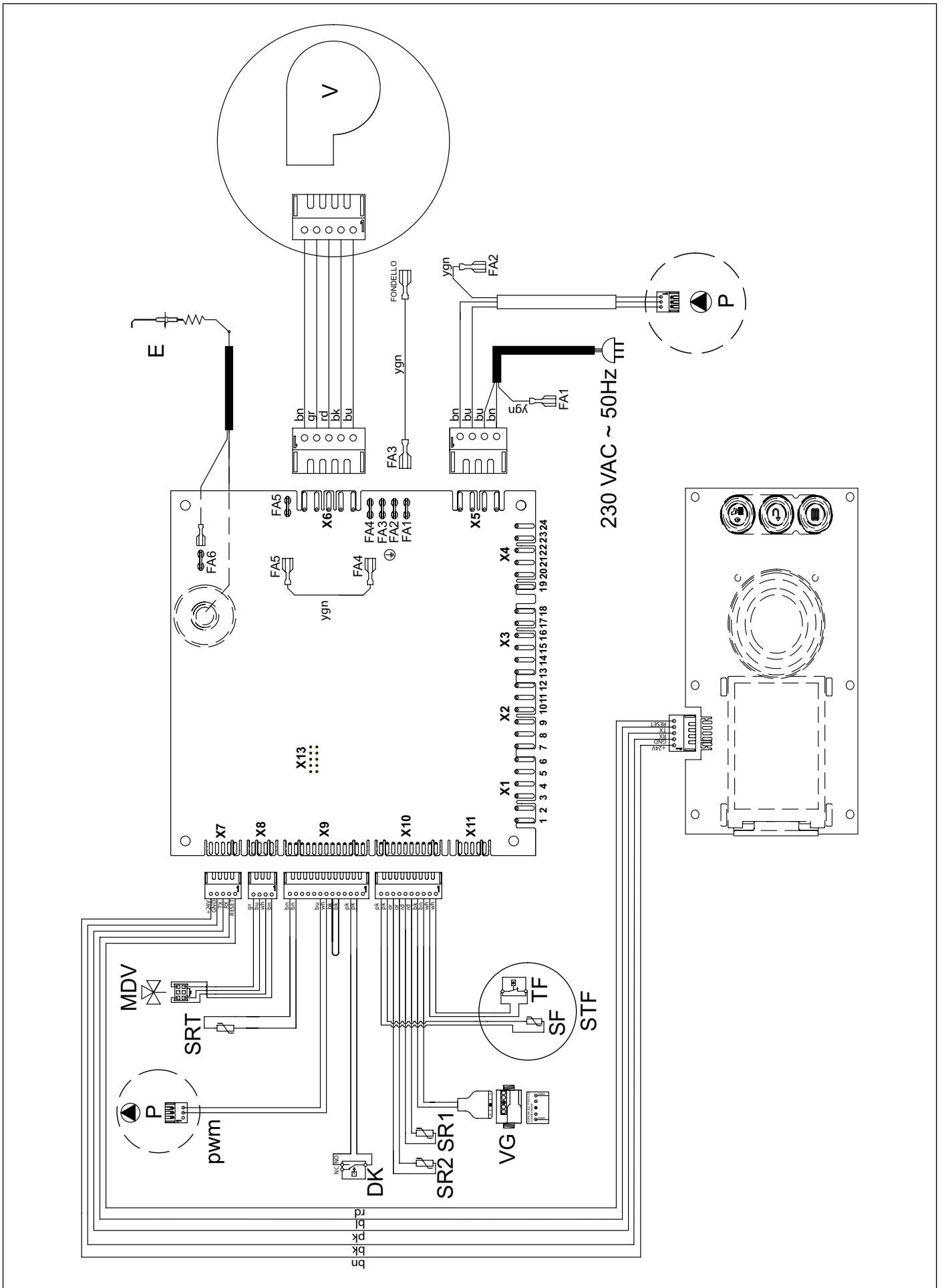

Fig. 33 Wiring diagram KRB (II)

Internal connections

- DK:** low water pressure switch
- FL:** flow switch
- SS:** DHW NTC 'OUT' probe 10k Ohm at 25°C B=3435
- SRT:** return NTC temperature probe 10k Ohm at 25°C B=3435
- SR1-SR2:** CH NTC temperature probe 10k Ohm at 25°C B=3435
- SF:** flue gas NTC probe 10k Ohm at 25°C B=3435
- TF:** flue gas thermostat
- STF:** flue gas probe and flue gas thermostat (SF+TF)
- VG:** gas valve
- P:** boiler circulation pump
- PWM:** PMW signal cable for circulation pump
- MDV:** electric deviating valve
- E:** ignition/flame detection electrode
- V:** brushless fan
- X1-X13:** Load/signal connectors
- FA1-FA6:** ground connectors

Connections performed by the installer

- 1-2:** room thermostat (TA) or ambient probe (SA) or separator probe (SDIS)
- 3-4:** room thermostat (TA) or Remote Control (REMOTO)
- 5-6:** outdoor temperature probe NTC 10k Ohm at 25 °C B=3977 (SEXT)
- 7-8:** boiler water heater probe (SBC, KR/KRB only)
- 9-10:** solar water heater probe (PT1000) (SBS)
- 11-12:** solar collector probe (PT1000) (SCS)
- 13-14:** low-temperature thermostat
- 15-16:** connection of the zone board bus
- 17-18:** IOT connection
- 19-20-21:** programmable relay (250 Vac 1A)
 - 19:** phase (NC)
 - 20:** phase (NO)
 - 21:** neutral (COMMON)
- 22-23-24:** programmable relay (250 Vac 1A)
 - 22:** neutral (COMMON)
 - 23:** phase (NC)
 - 24:** phase (NO)

2.21.1 Relationship between temperature and nominal resistance of all NTC probes (B=3435)

T (°C)	0	2	4	6	8
0	27203	24979	22959	21122	19451
10	17928	16539	15271	14113	13054
20	12084	11196	10382	9634	8948
30	8317	7736	7202	6709	6254
40	5835	5448	5090	4758	4452
50	4168	3904	3660	3433	3222
60	3026	2844	2674	2516	2369
70	2232	2104	1984	1872	1767
80	1670	1578	1492	1412	1336
90	1266	1199	1137	1079	1023

Tab. 31 Relationship between "Temperature and Nominal resistance" for temperature probes

2.22 Adaptation to other gas types and burner adjustment



WARNING

This boiler is built to run on the type of gas specified on the packaging and on the boiler rating plate. Any later transformation is to be exclusively carried out by qualified personnel, using manufacturer designed accessories and following the procedure and adjustment instructions for an accurate boiler setting-up.

- Disconnect the boiler from the electric power supply.
- Close the gas cock.
- Remove the plastic panel of the electrical panel.
- Remove boiler outer front panel.
- Rotate the electronic board box downwards.
- Disconnect the gas pipe from the gas valve (see Fig. 34 Gas diaphragm replacement).
- Replace the gas diaphragm (A) with the new gas type (see Fig. 34 Gas diaphragm replacement and Tab. 32 Gas diaphragm diameter (mm)).

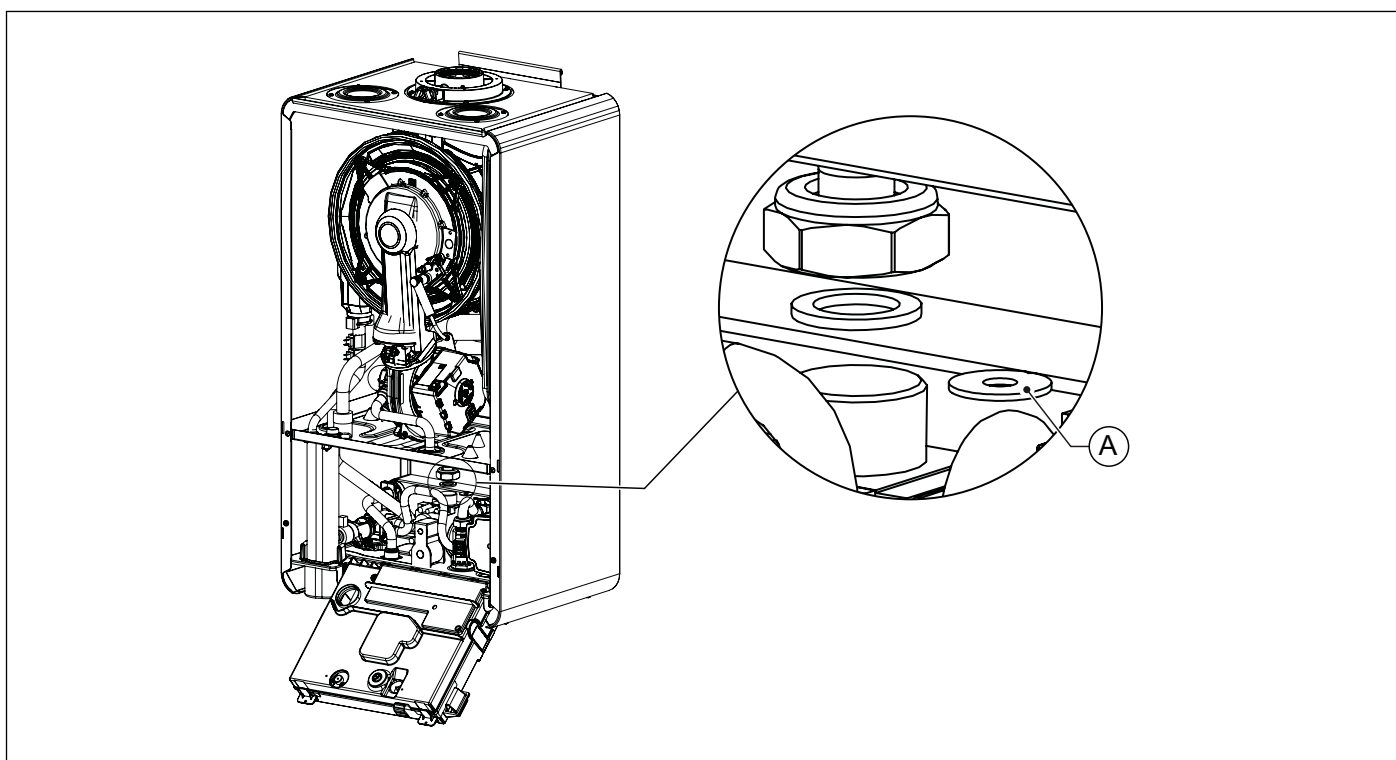

Fig. 34 Gas diaphragm replacement

Model	Natural gas	Propane
KC 18 - KR/KRB 12 kW	4,0	3,1
KC 26 - KR/KRB 24 kW	4,8	3,9
KC 30 - KR/KRB 28 kW	5,1	4,1
KC 35 - KR/KRB 32 kW	5,5	4,4

Tab. 32 Gas diaphragm diameter (mm)

- Check seal integrity; put it back in place or replace it if damaged.
- Reconnect the gas pipe to the gas valve and check gas circuit sealing.
- Refit the boiler outer front panel.
- Refit the plastic panel of the electrical panel.
- Reconnect boiler to electric power supply, and open the gas cock.
- Edit value for parameter **P0-TSP0** depending on boiler output (see par. *TSP parameters* on page 49).
- Adjust the gas valve (see par. *Gas valve setting* on page 67).

2.22.1 Gas valve setting



WARNING

In the case of a boiler connected to a gas distribution network that could receive a methane-hydrogen mixture of up to 20% (20%H₂NG) see paragraph *Mains gas valve setting 20%H₂NG* on page 69.

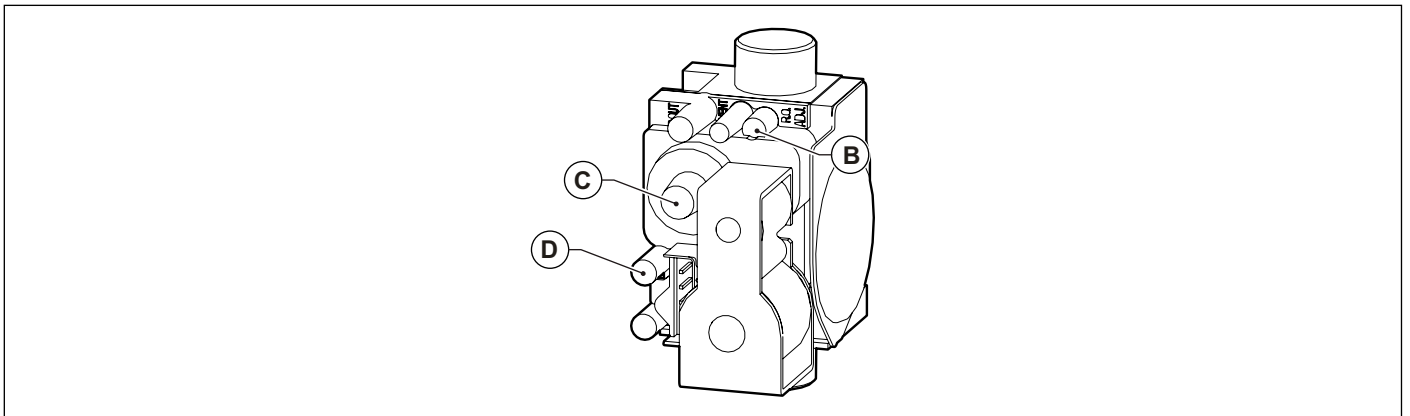

Fig. 35 Gas valve setting

2.22.1.1 Maximum heating output adjustment

- Make sure that the ambient thermostat (optional), if fitted, is set to **ON**.
- Start the "flue chimney" function (see *Flue cleaning function* on page 42). Set boiler max. output operation by turning the encoder until the value corresponding to fan max. speed for the output and boiler gas is displayed, according to Tab. 25 Limits to be set for TSP parameters and default values in relation to boiler type (TSP0) - I. The boiler starts operating at maximum heat output.
- If a gas switching has been made, access the programming page and set the parameter **P0** based on the output and on the supply gas, as specified in Tab. 25 Limits to be set for TSP parameters and default values in relation to boiler type (TSP0) - I.
- Check that **P4-P5-P6-P7** parameter values correspond to those specified in Tab. 25 Limits to be set for TSP parameters and default values in relation to boiler type (TSP0) - I.
- Remove the front panel and turn the control panel to gain access to the gas valve.
- Set flue gas (CO₂) content by turning the ratio adjuster **B** (see Fig. 35 Gas valve setting) and ensure that reading falls within the limits of Tab. 33 Flue gas CO₂ rate.
- Let boiler flue cleaning function on and continue with the next point "Minimum heating output adjustment" .

2.22.1.2 Minimum heating output adjustment

- Set boiler min. output operation by turning the encoder until the value corresponding to fan min. speed for the output and boiler gas is displayed, according to Tab. 25 Limits to be set for TSP parameters and default values in relation to boiler type (TSP0) - I.
- Boiler switches to min. output operation.
- Set flue gas (CO₂) content by turning the offset adjuster **C** (see Fig. 35 Gas valve setting) and ensure that reading falls within the limits of Tab. 33 Flue gas CO₂ rate.

2.22.1.3 Check with front panel closed



WARNING

It is necessary to check again the emissions with the front panel closed to ensure that there is no flue gas recirculation in the boiler.

- Return the electrical panel to its position and refit the boiler front panel.
- Check that the carbon dioxide (CO₂) value in the flue gas at minimum power is still within the limits of the Tab. 33 Flue gas CO₂ rate.
- Set again boiler max. output operation by turning the encoder until the value corresponding to fan max. speed for the output and boiler gas is displayed, according to Tab. 25 Limits to be set for TSP parameters and default values in relation to boiler type (TSP0) - I.
- Check that the carbon dioxide (CO₂) value in the flue gas at maximum power is still within the limits of the Tab. 33 Flue gas CO₂ rate.
- Keep key  pressed to end the flue cleaning function.

Model	Fuel	Supply pressure [mbar]	Diaphragm diameter [mm]	Flue CO ₂ value Max. output ⁽¹⁾ [%]	Flue CO ₂ value Min. output [%]
KC 18 KR 12 KRB 12	Natural gas G20	20	4,0	9,30 ± 0,45	9,00 ± 0,45
	Propane Gas G31	37	3,1	10,20 ± 0,45	9,00 ± 0,45
KC 26 KR 24 KRB 24	Natural gas G20	20	4,8	9,30 ± 0,45	8,10 ± 0,45
	Propane Gas G31	37	3,9	10,60 ± 0,45	9,20 ± 0,45
KC 30 KR 28 KRB 28	Natural gas G20	20	5,1	9,30 ± 0,45	8,10 ± 0,45
	Propane Gas G31	37	4,1	10,60 ± 0,45	9,20 ± 0,45
KC 35 KR 32 KRB 32	Natural gas G20	20	5,5	9,30 ± 0,45	8,30 ± 0,45
	Propane Gas G31	37	4,4	10,60 ± 0,45	9,20 ± 0,45

Tab. 33 Flue gas CO₂ rate

(1) DHW maximum heat input

2.22.2 Mains gas valve setting 20%H2NG



WARNING

In the case of a boiler connected to gas distribution mains, which could receive a methane-hydrogen mixture of up to 20% (20%H2NG), a combustion analyser with direct oxygen measurement must be used, regularly calibrated, and the adjustment must be made using the O₂ and offset pressure values as a reference.

For offset pressure measurement, use a differential pressure gauge with negative range measurement and an accuracy of at least +/- 1 Pa.

2.22.2.1 Maximum heating output adjustment

- Make sure that the ambient thermostat (optional), if fitted, is set to **ON**.
- Start the "flue chimney" function (see *Flue cleaning function* on page 42). Set boiler max. output operation by turning the encoder until the value corresponding to fan max. speed for the output and boiler gas is displayed, according to Tab. 25 Limits to be set for TSP parameters and default values in relation to boiler type (TSP0) - I. The boiler starts operating at maximum heat output.
- If a gas switching has been made, access the programming page and set the parameter **P0** based on the output and on the supply gas, as specified in Tab. 25 Limits to be set for TSP parameters and default values in relation to boiler type (TSP0) - I.
- Check that **P4-P5-P6-P7** parameter values correspond to those specified in Tab. 25 Limits to be set for TSP parameters and default values in relation to boiler type (TSP0) - I.
- Remove the front panel and turn the control panel to gain access to the gas valve.
- Turn the ratio adjuster **B** (see Fig. 35 Gas valve setting) to set flue gas oxygen content (O₂) until it falls within the limits of the Tab. 34 Flue gas O₂ rate.
- Let boiler flue cleaning function on and continue with the next point "Minimum heating output adjustment" .

2.22.2.2 Minimum heating output adjustment

- Set boiler min. output operation by turning the encoder until the value corresponding to fan min. speed for the output and boiler gas is displayed, according to Tab. 25 Limits to be set for TSP parameters and default values in relation to boiler type (TSP0) - I.
- Boiler switches to min. output operation.
- Open the screw of the offset pressure pick-up point **D** and connect it to the positive input (*) of the differential pressure gauge (see Fig. 36 Offset pressure adjustment).
- Turn the offset adjuster **C** (see Fig. 35 Gas valve setting) to set flue gas oxygen content (O₂) and offset pressure until they both fall within the limits of the Tab. 34 Flue gas O₂ rate.
- Remove the connection from the differential pressure gauge and retighten the screw of the offset pressure pick-up point **D**.

2.22.2.3 Check with front panel closed



WARNING

It is necessary to check again the emissions with the front panel closed to ensure that there is no flue gas recirculation in the boiler.

- Return the electrical panel to its position and refit the boiler front panel.
- Check that the oxygen (O₂) value in the flue gas at minimum power is still within the limits of the Tab. 34 Flue gas O₂ rate.
- Check that the carbon oxide (CO) value in the flue gas at minimum power is below the limit of the Tab. 34 Flue gas O₂ rate.
- Set again boiler max. output operation by turning the encoder until the value corresponding to fan max. speed for the output and boiler gas is displayed, according to Tab. 25 Limits to be set for TSP parameters and default values in relation to boiler type (TSP0) - I.
- Check that the oxygen (O₂) value in the flue gas at maximum power is still within the limits of the Tab. 34 Flue gas O₂ rate.
- Check that the carbon oxide (CO) value in the flue gas at maximum power is below the limit of the Tab. 34 Flue gas O₂ rate.
- Keep key  pressed to end the flue cleaning function.

(*) the connection to the positive input is linked to the condition that a differential pressure gauge is being used with measurement in the negative range

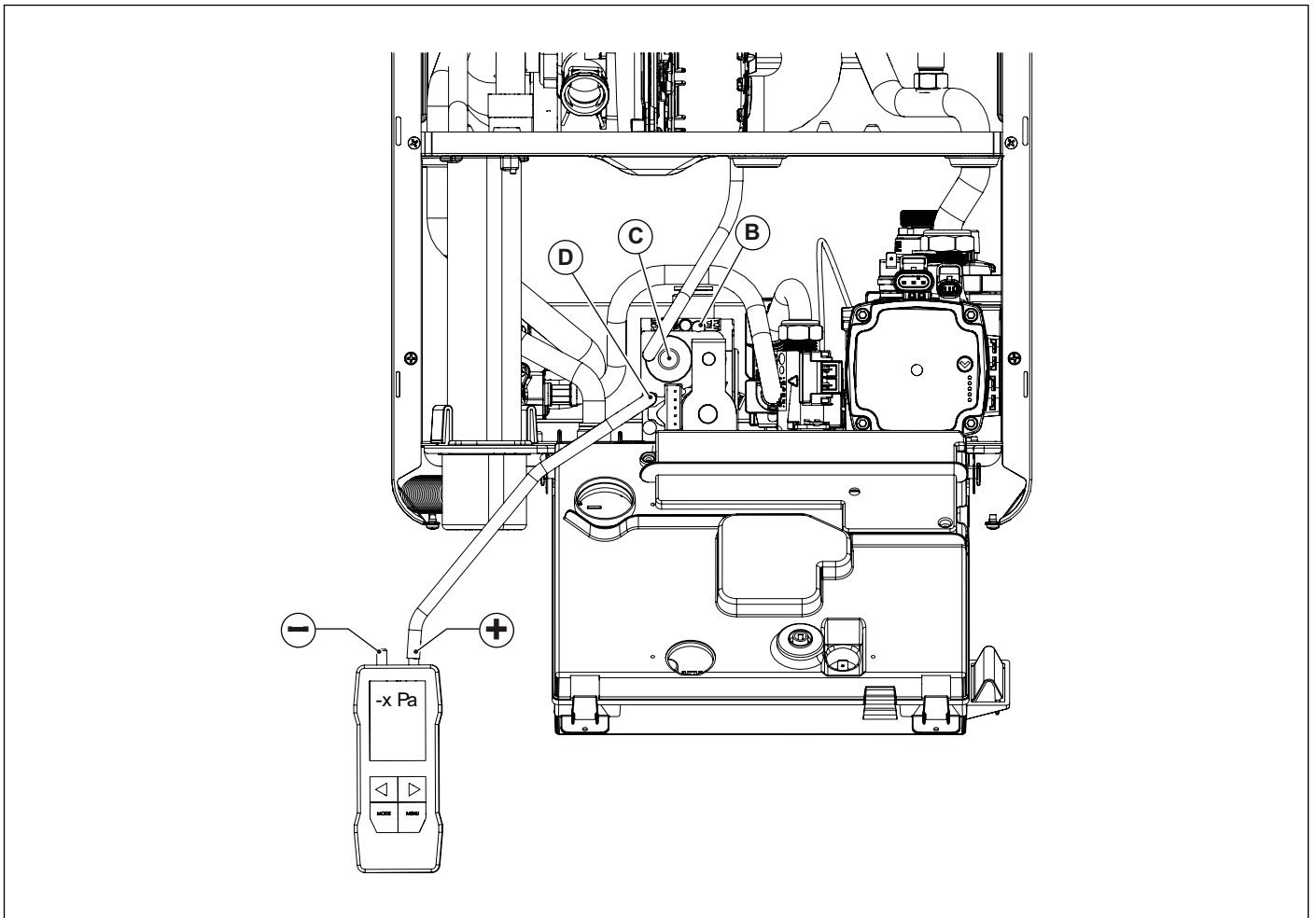

Fig. 36 Offset pressure adjustment

Model	Fuel	Supply pressure [mbar]	Diaphragm diameter [mm]	O ₂ value Q _{max} ⁽¹⁾ [%]	O ₂ value Q _{min} [%]	CO ⁽²⁾ maximum value [ppm]	Offset pressure Q _{min}	
							Lower limit [Pa]	Upper limit [Pa]
KC 18 KR 12 KRB 12	Natural gas G20 Mixture 20%H2NG	20	4,0	4,40 ± 0,80	4,90 ± 0,80	350	-15,0	-7,0
KC 26 KR 24 KRB 24	Natural gas G20 Mixture 20%H2NG	20	4,8	4,40 ± 0,80	6,50 ± 0,80	350	-15,4	-7,4
KC 30 KR 28 KRB 28	Natural gas G20 Mixture 20%H2NG	20	5,1	4,40 ± 0,80	6,50 ± 0,80	350	-14,5	-6,5
KC 35 KR 32 KRB 32	Natural gas G20 Mixture 20%H2NG	20	5,5	4,40 ± 0,80	6,10 ± 0,80	350	-14,4	-6,4

Tab. 34 Flue gas O₂ rate

(1) DHW maximum heat input

(2) Referred to corrected CO at Oxygen 0%

3. Testing the boiler



WARNING

The information in this section of the manual is for qualified personnel only.
The user is not authorised to carry out such operations.

3.1 Preliminary checks

Before testing the boiler, it is recommended to check the following:

- the flue gas venting duct and the relative terminal are installed in conformity with the instructions: **with the boiler operating, there must be no leakage of combustion by-products from any of the gaskets.**
- the supply power to the boiler must be 230 V ~ 50 Hz;
- the system is correctly filled with water (pressure gauge reading 1 to 1.3 bar);
- any shut-off cocks in the system pipes are open;
- the mains gas type is correct for the boiler calibration: convert the boiler to the available gas when necessary; this operation must only be performed by qualified technical personnel;
- the gas supply cock is open;
- **there are no fuel gas leaks;**
- the main switch installed ahead of the boiler is turned on;
- the 3-bar safety valve is not stuck;
- there are no water leaks;
- the condensate trap installed on the boiler is discharging condensate correctly and is not stuck.



WARNING

Should the boiler not be installed in compliance with the prevailing laws and standards, notify the system supervisor and do not test the boiler.

3.2 Switching on and switching off

To switch the boiler on and off, refer to the “Instructions for the User”.

4. Maintenance



WARNING

The information in this section of the manual is for qualified personnel only.
The user is not authorised to carry out such operations.



WARNING

Any maintenance (and repair) work must only be carried out by qualified personnel.



WARNING

A proper boiler routine maintenance is an essential requirement to ensure safety.

The user is strongly advised to have the product serviced and repaired by a service centre or qualified personnel.



WARNING

Appropriate boiler maintenance ensures efficient operation, environment preservation, and safety for people, animals and objects.

The boiler must be serviced at least once every year.



WARNING

Disconnect electric power supply before starting any maintenance procedure, involving replacement of components and/or cleaning inside parts of boiler.

4.1 Maintenance schedule

Maintenance operations include check and cleaning procedures. In particular:

Inspections and checks

- Check general integrity of the boiler.
- Check boiler and network gas supply for leakage.
- Check gas supply pressure to boiler.
- Check boiler ignition sequence.
- Check boiler combustion parameters by flue gas analysis.
- Check the condition and seal integrity of the flue gas venting pipes.
- Check the state of combustion fan.
- Check integrity of safety devices of the boiler in general.
- Check for water leaks and oxidised areas on the boiler's couplings.
- Check efficiency of the system safety valves.
- Check expansion vessel filling pressure.
- Check correct draining of condensate from the condensate trap installed on the boiler.

The following cleaning is to be done

- Clean the general interior of the boiler.
- Clean the air intake and flue gas venting circuits.
- Clean the heat exchanger.
- Clean the condensate trap and discharge ducts.
- Cleaning system filters (if any).

When checking the boiler for the very first time, also verify:

- Boiler room suitability.
- Diameter and length of flue gas system ducts.
- Boiler installation in accordance to the instructions in this manual.



WARNING

Should the device not operate correctly, while not posing danger to people, animals or property, or should you find any discrepancy with reference to prevailing standards and regulations, notify the system supervisor both verbally and in writing.



WARNING

The manufacturer shall not be held responsible for damage to people, animals, or property due to tampering with or improper intervention to the boiler or failed/insufficient maintenance.

4.2 Combustion analysis

The combustion parameters of the boiler, which have to be checked in order to determine efficiency and emissions, must be measured in compliance with applicable legislation and standards.

4.3 Extraordinary maintenance

Extraordinary maintenance includes changing equipment components that are worn out or broken.



WARNING

Strictly comply with the instructions below.

Gas valve

The seals between gas valve and gas pipes must be replaced. And then checked for sealing.

The tightening torque for gas pipe fittings must be 23 Nm.

Gas valve calibration is mandatory: for calibration operations please strictly follow the procedures in paragraphs *Gas valve setting* on page 67, for details on these topics.

The perfect sealing of valve pressure taps must be checked.

Flame electronic control board

It is mandatory to set up the electronic board according to the boiler model, based on the instructions supplied together with the board. In case of loss or doubts, contact the boiler manufacturer.

It is mandatory to set up the spare electronic board based on the gas type for which boiler is preset and its power.

For configuration, carefully follow the procedures in paragraph *TSP parameters* on page 49, to set parameter P0.

Make sure that all wirings have been correctly connected according to the wiring diagrams in paragraph *Wiring diagrams* on page 59.

Safety thermostats and temperature probes

Spare part must be perfectly fastened and adhere to the element whose temperature must be measured.

Combustion fan

It is mandatory to properly position the seals in their seats and change any old ones with the new ones supplied together with the spare part.

Fasten the fan plate using all screws and check sealing.

Heat exchanger

In case of operations involving removing and/or changing the heat exchanger, all affected seals must be changed and sealing checked and ensured.

Ignition and flame detection electrodes

In case of operations involving removing and/or changing the electrode, all affected seals must be changed and sealing checked and ensured.

Hydraulic components

In case of operations involving removing and/or changing any hydraulic components, all affected seals must be changed and sealing checked and ensured to avoid water leakage.

5. Decommissioning, disassembly and disposal



WARNING

Gas boilers are electrical and electronic equipment (EEE) and when decommissioned they become waste electrical and electronic equipment (WEEE), therefore, they must be disposed of in compliance with the legislation in force in the country of installation.

Gas boilers are classified as domestic appliances and must be disposed of in the same way as washing machines, dish washers and tumble dryers (R4 WEEE waste).

The disassembly of gas boilers and their disposal is therefore forbidden through channels not specifically provided for by law.

Decommissioning, disassembly and disposal operations must be performed with boiler cold and disconnected from gas and power mains.



WARNING

The user is not authorised to carry out such operations.



6. Malfunctions, possible causes and solutions

6.1 Troubleshooting

BOILER STATUS	MALFUNCTION	PROBABLE CAUSE	User's tasks	Qualified personnel's tasks	
E01*	Burner does not ignite.	Gas supply failure.	Check gas supply. Check gas supply cock opening or gas network safety valve intervention.		
		Gas valve is disconnected.	Contact qualified personnel	Reconnect it.	
		Gas valve is faulty.	Contact qualified personnel	Replace it.	
		The electronic board is faulty.	Contact qualified personnel	Replace it.	
	Burner does not ignite: no spark.	Ignition electrode is faulty.	Contact qualified personnel	Replace the electrode.	
		Ignition transformer is faulty	Contact qualified personnel	Replace the ignition transformer.	
		Electronic board does not ignite. It is faulty.	Contact qualified personnel	Replace electronic board.	
	Burner ignites for a few seconds and goes off.	Electronic board does not detect flame: inverted phase and neutral.	Contact qualified personnel	Verify correct neutral and phase connection.	
		Detection electrode cable is interrupted.	Contact qualified personnel	Reconnect or replace cable.	
		Detection electrode is faulty.	Contact qualified personnel	Replace the electrode.	
		Electronic board does not detect flame: it is faulty.	Contact qualified personnel	Replace electronic board.	
		Ignition heat input setting is too low.	Contact qualified personnel	Increase it	
		Minimum heat input is not set correctly.	Contact qualified personnel	Check burner setting.	
E02*	Flow temperature exceeded the max. allowed value.	Circulation pump is faulty.	Contact qualified personnel	Replace it.	
		Circulation pump is seized.	Contact qualified personnel	Check pump electrical connection.	
E03*	Flue thermostat triggering.	Poor flue draught.	Contact qualified personnel	Check air intake or flue gas venting system and vent grilles in the boiler room.	
		Flue vent/air intake duct is obstructed.	Contact qualified personnel	Check for any duct obstruction, and eliminate it.	
		Flue gas thermostat is faulty.	Contact qualified personnel	Replace it.	

BOILER STATUS	MALFUNCTION	PROBABLE CAUSE	User's tasks	Qualified personnel's tasks
E04**	CH system water pressure is low.	The system has been recently bled.	Fill the system (see section Boiler shut-down). If the error occurs again several times, contact a qualified Service Centre or qualified personnel.	
		The system is leaking.	Check system.	
		Pressure transducer is disconnected.	Contact qualified personnel	Reconnect it.
		Pressure transducer is faulty.	Contact qualified personnel	Replace it.
E05**	Flow probe failure.	Flow probe is electrically disconnected.	Contact qualified personnel	Reconnect it.
		Flow probe faulty.	Contact qualified personnel	Replace it.
E06**	DHW probe failure (CTFS) (KC only).	DHW probe is electrically disconnected.	Contact qualified personnel	Reconnect it.
		DHW probe faulty.	Contact qualified personnel	Replace it.
E06**	Water heater probe failure (KR/KRB with optional external water heater fitted with NTC probe).	Probe is disconnected.	Contact qualified personnel	Reconnect it.
		Probe is faulty.	Contact qualified personnel	Replace it.
E07**	Flue gas probe failure.	Flue probe is electrically disconnected.	Contact qualified personnel	Reconnect it.
		Flue probe is faulty.	Contact qualified personnel	Replace it.
E14**	Faulty separator probe	Disconnected or short-circuited probe.	Contact qualified personnel	Reconnect it or replace it.
			Contact qualified personnel	Check parameter P89.
E15**	Return probe failure.	Probe is disconnected.	Contact qualified personnel	Reconnect it.
		Probe is faulty.	Contact qualified personnel	Replace it.
E24**	SCS solar collector probe fault	Disconnected or faulty probe.	Contact qualified personnel	Reconnect it or replace it.
		Probe detects a value lying outside the admissible range.	Contact qualified personnel	Make sure the probe is of PT1000 type.
E28**	SBS solar water heater probe fault	Disconnected or faulty probe.	Contact qualified personnel	Reconnect it or replace it.
		Probe detects a value lying outside the admissible range.	Contact qualified personnel	Make sure the probe is of PT1000 type.
E31**	Remote Control connection failure (only shown on Remote Control display).	The Remote Control is not connected to boiler board.	Contact qualified personnel	Reconnect it.
		Remote control faulty.	Contact qualified personnel	Replace it.
		Boiler board is faulty.	Contact qualified personnel	Replace it.

BOILER STATUS	MALFUNCTION	PROBABLE CAUSE	User's tasks	Qualified personnel's tasks
E35**	Triggering of boiler low-temperature safety thermostat.	Boiler flow temperature not properly set.	Contact qualified personnel	Check curve parameters.
		Thermostat is disconnected.	Contact qualified personnel	Reconnect it.
		Thermostat is faulty.	Contact qualified personnel	Replace it.
		Flow sensors disconnected or not properly attached to the pipe.	Contact qualified personnel	Reconnect or reposition them.
		Faulty board.	Contact qualified personnel	Replace it.
E36**	Flow probe failure in mixed zone 2. (with zone kit installed, only).	Probe is disconnected.	Contact qualified personnel	Reconnect it or replace it.
		Probe is faulty.	Contact qualified personnel	Make sure the probe is of NTC type.
E37**	Flow probe failure in mixed zone 3. (with zone kit installed, only).	Probe is disconnected.	Contact qualified personnel	Reconnect it or replace it.
		Probe is faulty.	Contact qualified personnel	Make sure the probe is of NTC type.
E38**	Triggering of low-temperature safety thermostat in mixed zone 2.	Boiler flow temperature not properly set.	Contact qualified personnel	Check curve parameters.
		Thermostat is disconnected.	Contact qualified personnel	Reconnect it.
		Thermostat is faulty.	Contact qualified personnel	Reconnect it.
		Flow sensors disconnected or not properly attached to the pipe.	Contact qualified personnel	Reconnect or reposition them.
		Faulty board.	Contact qualified personnel	Replace it.
E39**	Triggering of low-temperature safety thermostat in mixed zone 3.	Boiler flow temperature not properly set.	Contact qualified personnel	Check curve parameters.
		Thermostat is disconnected.	Contact qualified personnel	Reconnect it.
		Thermostat is faulty.	Contact qualified personnel	Reconnect it.
		Flow sensors disconnected or not properly attached to the pipe.	Contact qualified personnel	Reconnect or reposition them.
		Faulty board.	Contact qualified personnel	Replace it.
E40*	Fan failure.	Fan disconnected.	Contact qualified personnel	Reconnect it.
		Fan faulty.	Contact qualified personnel	Replace it.
E41**	No communication between board and peripheral devices (zone/interface boards).	Zone boards are not connected.	Contact qualified personnel	Reconnect them.
		Zone boards are faulty.	Contact qualified personnel	Replace them.

BOILER STA-TUS	MALFUNCTION	PROBABLE CAUSE	User's tasks	Qualified personnel's tasks
E43**	Input configuration error.	Presence of a remote control instead of a room thermostat.	Contact qualified personnel	Check parameters P61, P77 and P89.
E44**	The ambient probe does not work.	Probe is disconnected.	Contact qualified personnel	Reconnect it.
		Probe is faulty.	Contact qualified personnel	Replace it.
E47**	The external probe does not work.	Probe is disconnected.	Contact qualified personnel	Reconnect it.
		Probe is faulty.	Contact qualified personnel	Replace it.
E61**	Faulty zone 1 ambient probe. (only with zone board connected).	Disconnected or short-circuited probe.	Contact qualified personnel	Reconnect it or replace it.
			Contact qualified personnel	Check parameter P61.
E62**	Faulty zone 2 ambient probe. (only with zone board connected).	Disconnected or short-circuited probe.	Contact qualified personnel	Reconnect it or replace it.
			Contact qualified personnel	Check parameter P61.
E63**	Faulty zone 3 ambient probe. (only with zone board connected).	Disconnected or short-circuited probe.	Contact qualified personnel	Reconnect it or replace it.
			Contact qualified personnel	Check parameter P61.
E78**	Too high flow derivative.	Any cut-off valves are closed.	Contact qualified personnel	Check system.
		Circulation pump is blocked.	Contact qualified personnel	Check the circulation pump.
		Low water flow rate.	Contact qualified personnel	Check system pressure or for any exchanger clogging.
		Faulty or clogged by-pass.	Contact qualified personnel	Check the by-pass.
E85*	Return probe > 105°C.	No circulation in the boiler.	Contact qualified personnel	Check the pump or the by-pass.
		Return probe incorrectly calibrated or faulty.	Contact qualified personnel	Replace the probe.
E88**	Power reduction for flue gas high temperature.	Primary exchanger clogged.	Contact qualified personnel	Clean or replace the primary exchanger.
E99	The max. number of resets from the Remote Control or interface has been reached.	The user has reached the max. number of error reset attempts from the Remote Control or interface.	Press key 	Press key 
E151*	GV_CURR_LOCKOUT	Gas valve disconnected or faulty.	Contact qualified personnel	Check the gas valve.
		Faulty boiler board.	Contact qualified personnel	Replace the board.

BOILER STATUS	MALFUNCTION	PROBABLE CAUSE	User's tasks	Qualified personnel's tasks
E158*	APS_LOCKOUT	Fan disconnected.	Contact qualified personnel	Check the fan.
		Faulty boiler board.	Contact qualified personnel	Replace the board.
E160*	MAX_TRIALS_LOCKOUT	See indications for E01.	See indications for E01.	See indications for E01.
E162**	Flow probe > 95 °C.	Water does not circulate inside heating system.	Contact qualified personnel	Check system status.
		Circulation pump is blocked or faulty.	Contact qualified personnel	Check the circulation pump.
		One of the two flow probes is faulty.	Contact qualified personnel	Check flow probes.

* errors that can be reset by the user by keeping pressed the button ↵

** self-resettable errors, they automatically reset as soon as the failure is fixed

*** errors that can be reset only by the Technical Service personnel

In case errors **E90** and **E91** shall occur, please contact a service centre or qualified personnel for maintenance.



Fondital S.p.A. - Società a unico socio
25079 VOBARNO (Brescia) Italy - Via Cerreto, 40
Tel. +39 0365 878 31
Fax +39 0365 878 304
e-mail: info@fondital.it
www.fondital.com

The manufacturer reserves the right to modify his/her products as deemed necessary, without altering the basic characteristics of the products themselves.

Uff. Pubblicità Fondital IST 03 C 1722 - 01 | Luglio 2024 (07/2024)