

# ANTEA NEXT KRB

WALL-HUNG CONDENSING BOILER, CH ONLY, WITH  
INTEGRATED 3-WAY VALVE

CONNECTION TO AN EXTERNAL HOT WATER STORAGE TANK (OPTIONAL)





- ▶ **CeramiXSteel combustion unit:**
- ▶ **HIGH DURABILITY EXCHANGER:** thanks to the all-stainless steel single coil and large passage section, it avoids clogging and guarantees high performance over time
- ▶ **CERAMIC QUALITY:** high-performance ceramic burner allowing a wider modulation range
- ▶ **ADVANCED ELECTRONICS:** intuitive and functional with large colour display
- ▶ **EASY INSTALLATION:** simple and practical fixing and maintenance
- ▶ **ALTERNATIVE SOURCES CONFIGURATION:** through an intelligent algorithm it acts as a control unit for alternative energy sources
- ▶ **SMART CONNECTION:** can be connected to bms (integrated Modbus) and IOT building automation systems
- ) **COMBINED COMFORT:** thanks to the room temperature probe, the functioning is adapted to the room temperature without the use of a thermostat
- ) **SOLAR PRO FUNCTION:** enables the management of a solar thermal system
- ) **HIGH ELECTRICAL INSULATION:** thanks to the IPX5D electrical insulation rating it can be installed outdoors in partially protected locations
- ) **HIGH EFFICIENCY:** thanks to the 1:9 modulation ratio, high performance is guaranteed
- ) **CUSTOMIZABLE OPERATING:** weekly programmable



## USER INTERFACE

- ▶ Day/night temperature level selection
- ▶ Timer and ambient temperature setting

Available in the following models:



Model	Gas type	Code	Heat input		Energy efficiency class	W x H x D	Gross weight
			Nominal (Qn) kW	Nominal DHW kW	Room heating	mm	kg
<b>KRB 12</b>	NATURAL GAS	KAGXX2KU12	12,0	18,0 (*)	<b>A</b>	400x750x315	29,5
	PROPANE	KAGXX6KU12					
<b>KRB 24</b>	NATURAL GAS	KAGXX2KU24	23,7	27,3 (*)	<b>A</b>	400x750x315	29,5
	PROPANE	KAGXX6KU24					
<b>KRB 28</b>	NATURAL GAS	KAGXX2KU28	26,7	30,4 (*)	<b>A</b>	400x750x315	31,5
	PROPANE	KAGXX6KU28					
<b>KRB 32</b>	NATURAL GAS	KAGXX2KU32	30,4	34,5 (*)	<b>A</b>	400x750x315	32,0
	PROPANE	KAGXX6KU32					

(\*) with optional hot water storage tank.

**Included in the price:** Paper installation template, aspiration closing plugs.

## DIMENSIONS AND CONNECTION CENTRE DISTANCES

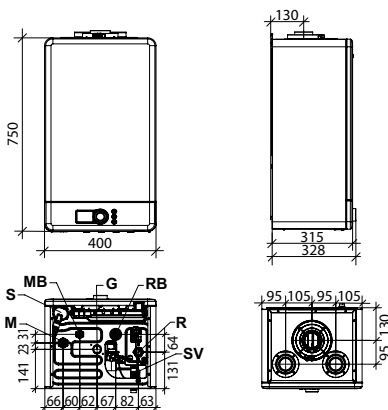

**S** Trap inspection cap

**M** CH system flow (3/4")

**MB** Secondary flow to storage tank (1 1/2")

**SV** 3-bar safety valve drain

**G** Gas inlet (3/4")

**RB** Secondary return from hot water storage tank (1/2")

**R** CH system return (3/4")





Technical data	um	KRB 12	KRB 24	KRB 28	KRB 32
Rated output (Pn)	kW	12	23	26	30
Seasonal energy efficiency of ambient heating ( $\eta_s$ )	%	92	92	92	91
Nominal heat input (Qn)	kW	12,0	23,7	26,7	30,4
Nominal heat output (80-60°C) (Pn)	kW	11,8	23,1	26,0	29,6
Heat output (50-30°C)	kW	12,9	25,0	28,1	32,2
Reduced heat input (Qr)	kW	2,0	3,0	3,3	4,2
Useful efficiency at nominal input (80-60°C)	%	98,0	97,3	97,3	97,3
Useful efficiency at nominal input (50-30°C)	%	107,5	105,5	105,4	105,9
Useful efficiency at 30% (30°C return)	%	108,3	108,4	108,0	107,8
Heating expansion vessel capacity	l	9	9	9	9
DHW nominal heat input	kW	18,0 (*)	27,3 (*)	30,4 (*)	34,5 (*)
NOx emission class	-	6	6	6	6
Electric protection rating	IP	IPX5D	IPX5D	IPX5D	IPX5D

(\*) with optional hot water storage tank.

Item	Description	Code	Item	Description	Code				
	Coaxial kit Ø 60/100 length 75cm	0CONDASP00		External probe (60x45x31 mm)	0SONDAES01				
	Remote control, ErP V class (118x85x32 mm)	0CREMOTO04		Basic hydraulic kit Next boilers	0KITIDBA30				
	Thermostat starter kit + Spot gateway	0SPOTAPP01		Covering pipes and boiler taps Next (*)	0COPETUB08				
	Zone expansion for Spot thermostat	0EXPSPOT01		NTC probe kit for 10k beta 3977 circuit breaker (*)	0KITSOND01				
	Coaxial fitting kit Ø60/100	0KITATCO00		PT 1000 probe kit with ring connection (*)	0KITSOPT00				
	Splitter kit Ø80+80	0KITSDOP08	<b>Accessories supplied as standard</b> <table border="1"> <thead> <tr> <th>Item</th> <th>Description</th> </tr> </thead> <tbody> <tr> <td></td> <td>hot water storage tank temperature probe 3m</td> </tr> </tbody> </table>			Item	Description		hot water storage tank temperature probe 3m
Item	Description								
	hot water storage tank temperature probe 3m								
	Magnetic dirt separator filter	0AFILDEF00							
	Ambient temperature probe	0KITSAMB00							

(\*) Items normally not in stock, minimum stock availability time 8 weeks.

Note: For more information, visit our website [www.fondital.com](http://www.fondital.com)



## How to increase energy efficiency?

Discover the most suitable solution

Seasonal energy efficiency of ambient heating ( $\eta_s$ )						
Regulation device		Code	KRB 12	KRB 24	KRB 28	KRB 32
<b>Option 1</b>	Boiler + external probe	<b>0SONDAES01</b>	94%	94%	94%	93%
<b>Option 2</b>	Boiler + room temperature probe	<b>0KITSAMB00</b>	95%	95%	95%	94%
<b>Option 3</b>	Boiler + external probe + room temperature probe	<b>0KITSAMB00</b>	96%	96%	96%	95%
		<b>0SONDAES01</b>				
<b>Option 4</b>	Boiler + remote control	<b>0CREMOTO04</b>	95%	95%	95%	94%
<b>Option 5</b>	Boiler+ remote control + external probe	<b>0CREMOTO04</b>	96%	96%	96%	95%

