

ESPLOSO E LISTA RICAMBI

SPARE PARTS LIST

fondital

NIAS DUAL LINE TECH

BTFS 24-28-32

BTN 24



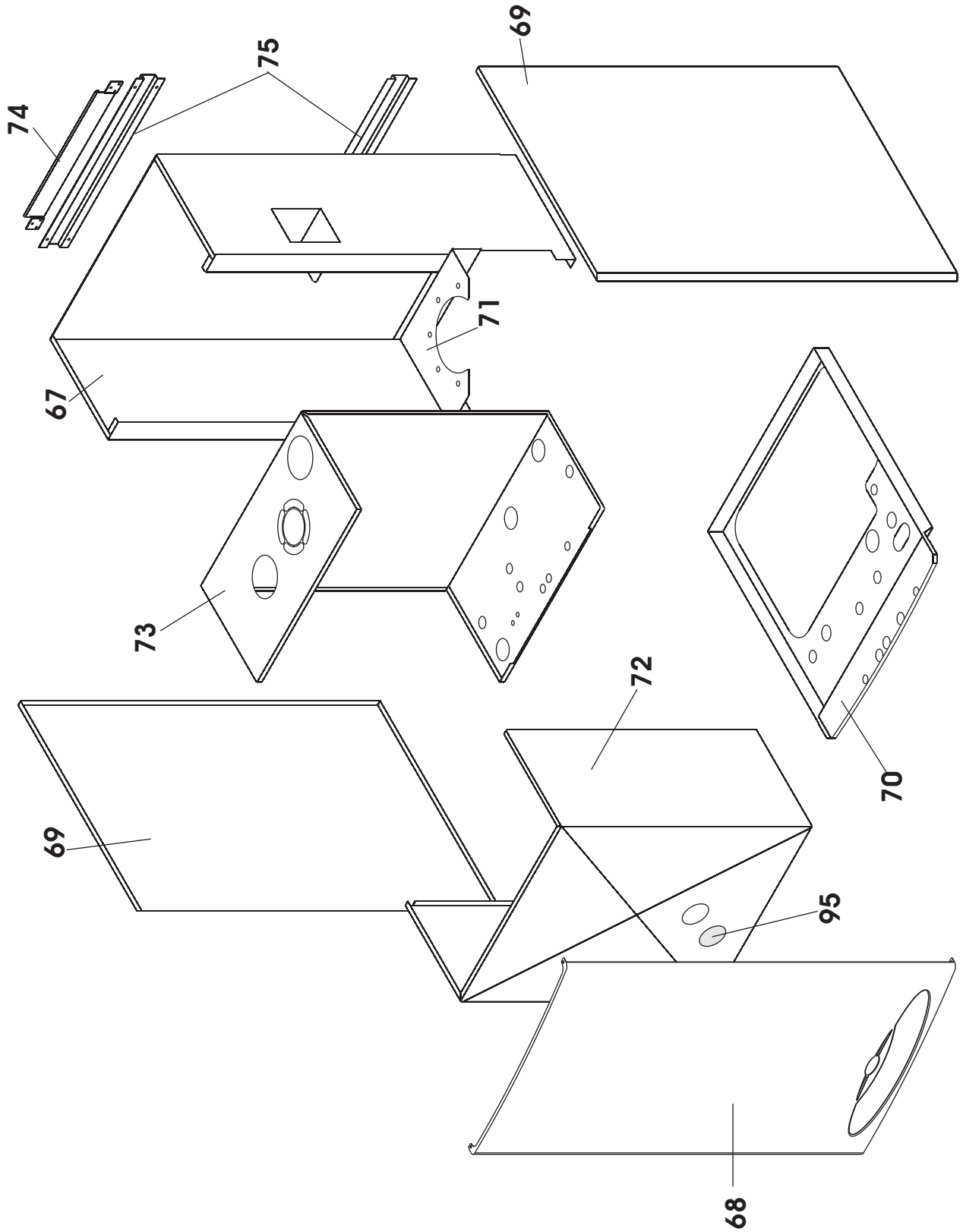

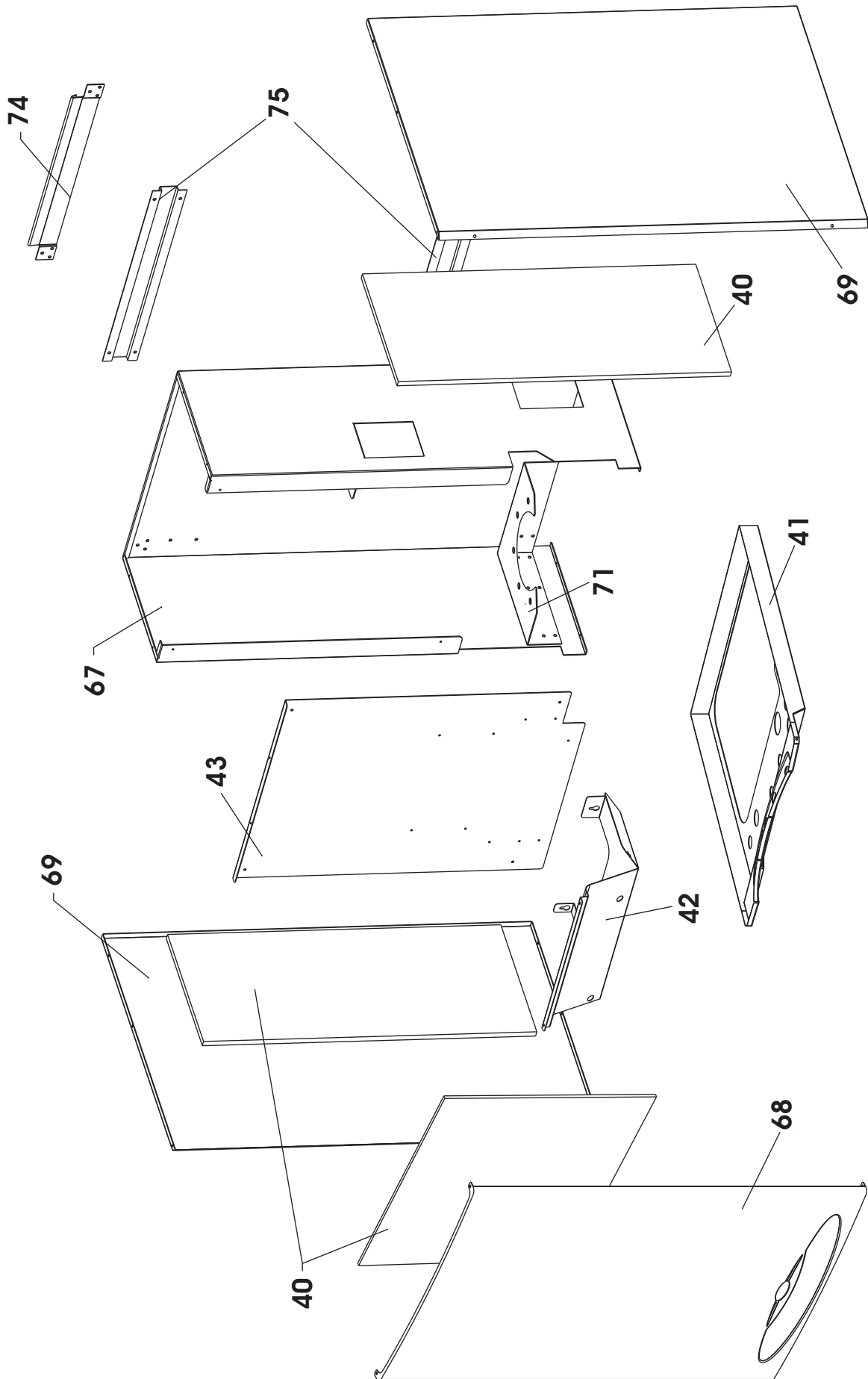

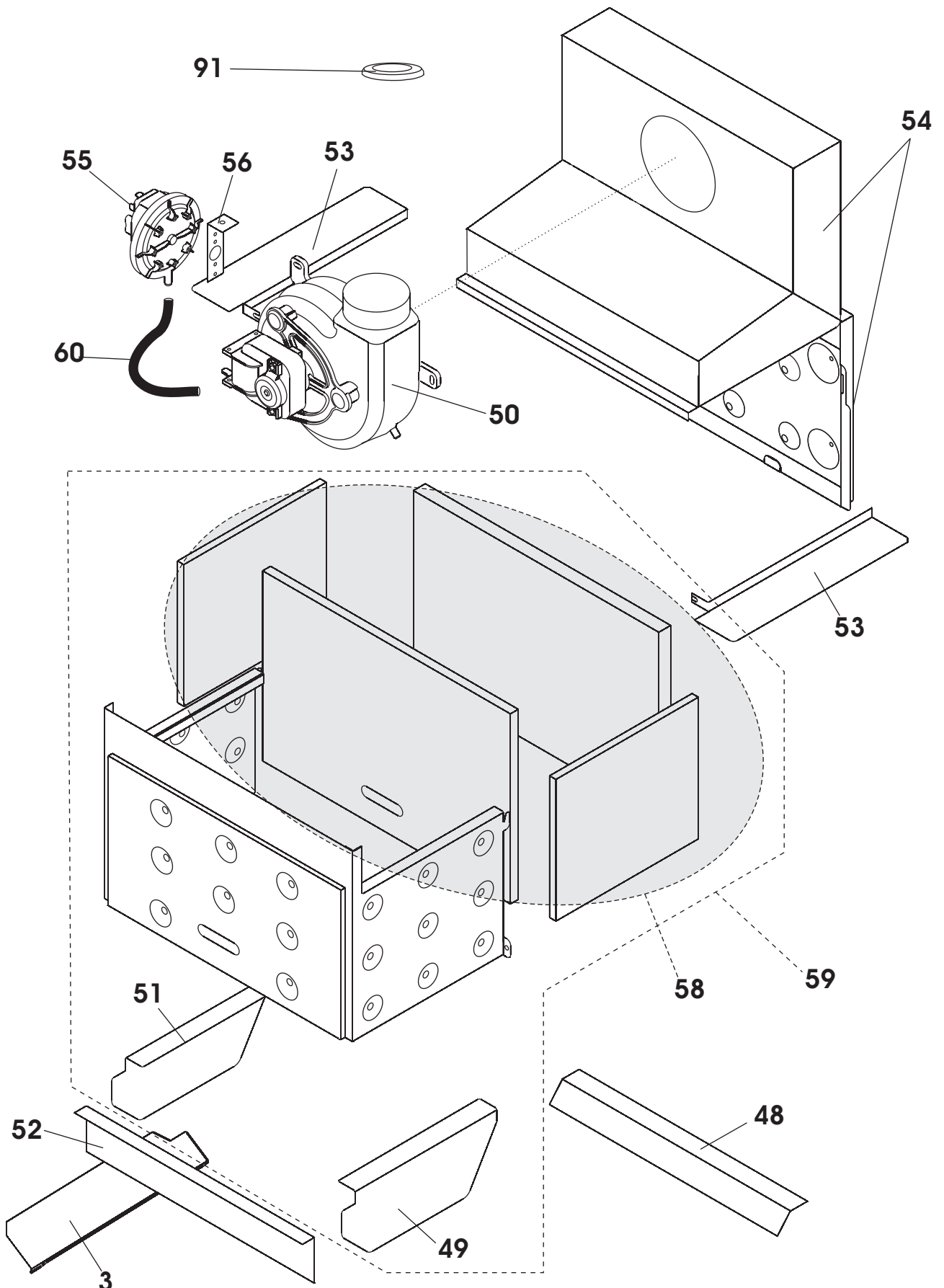

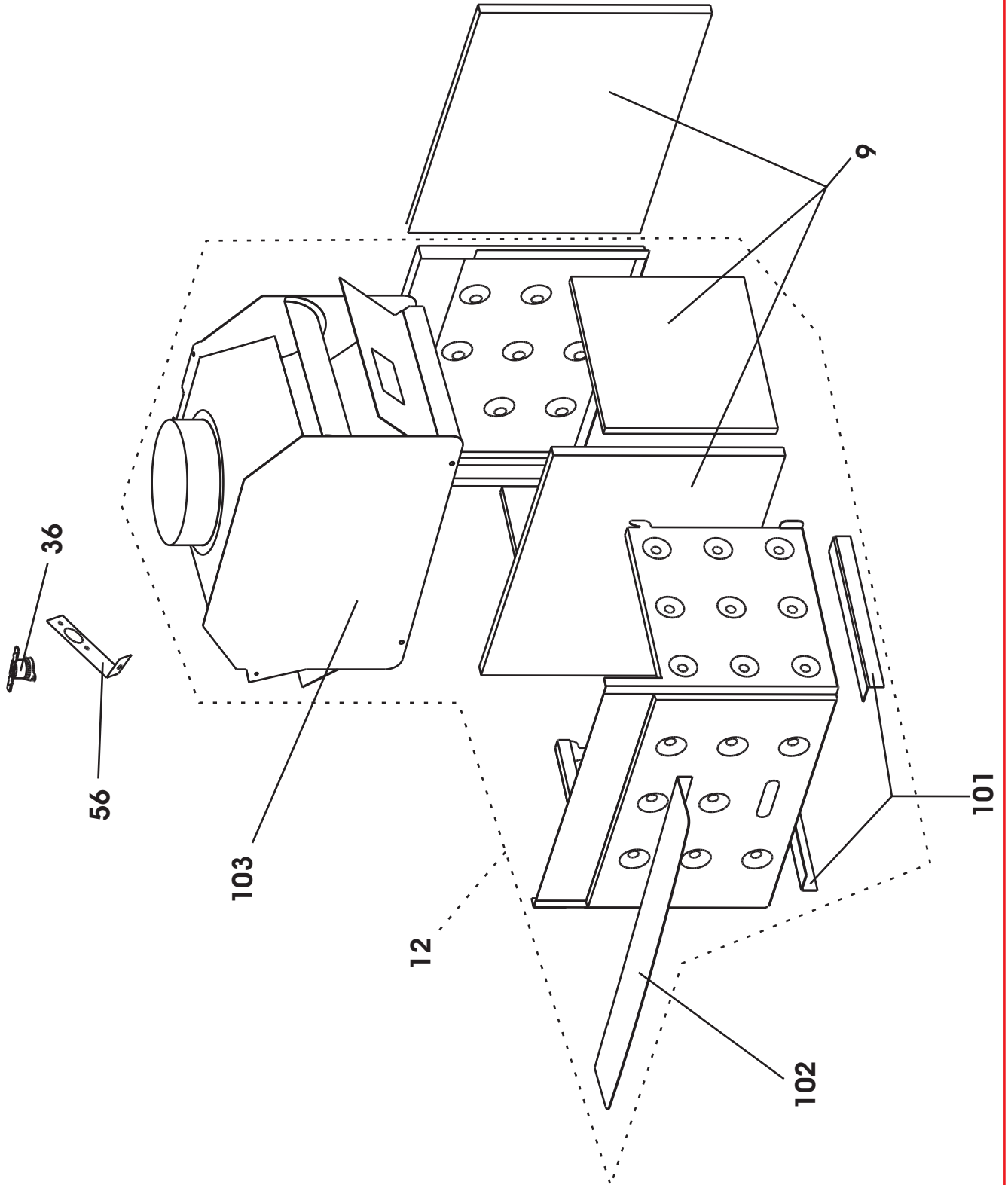
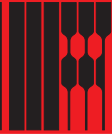

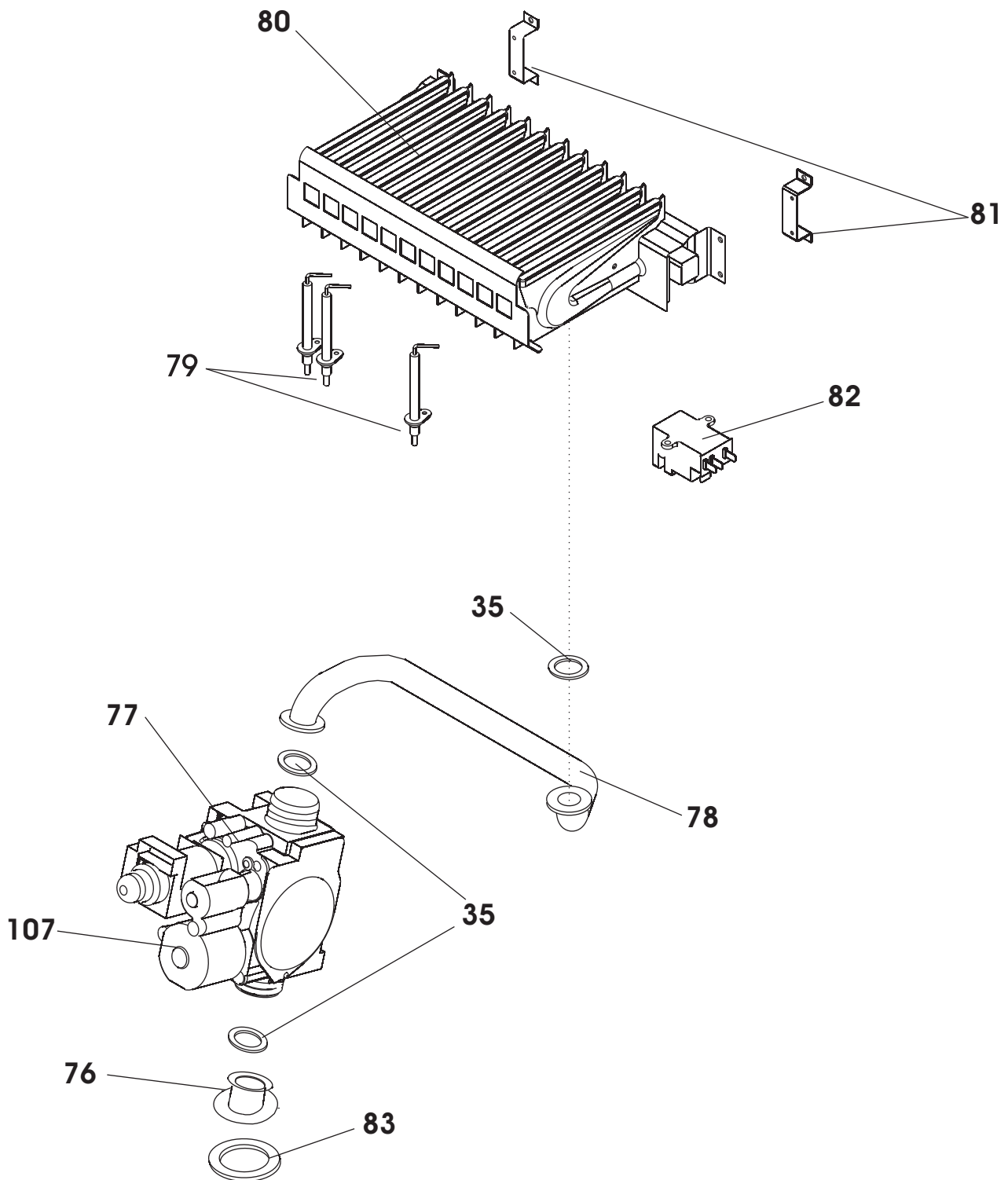

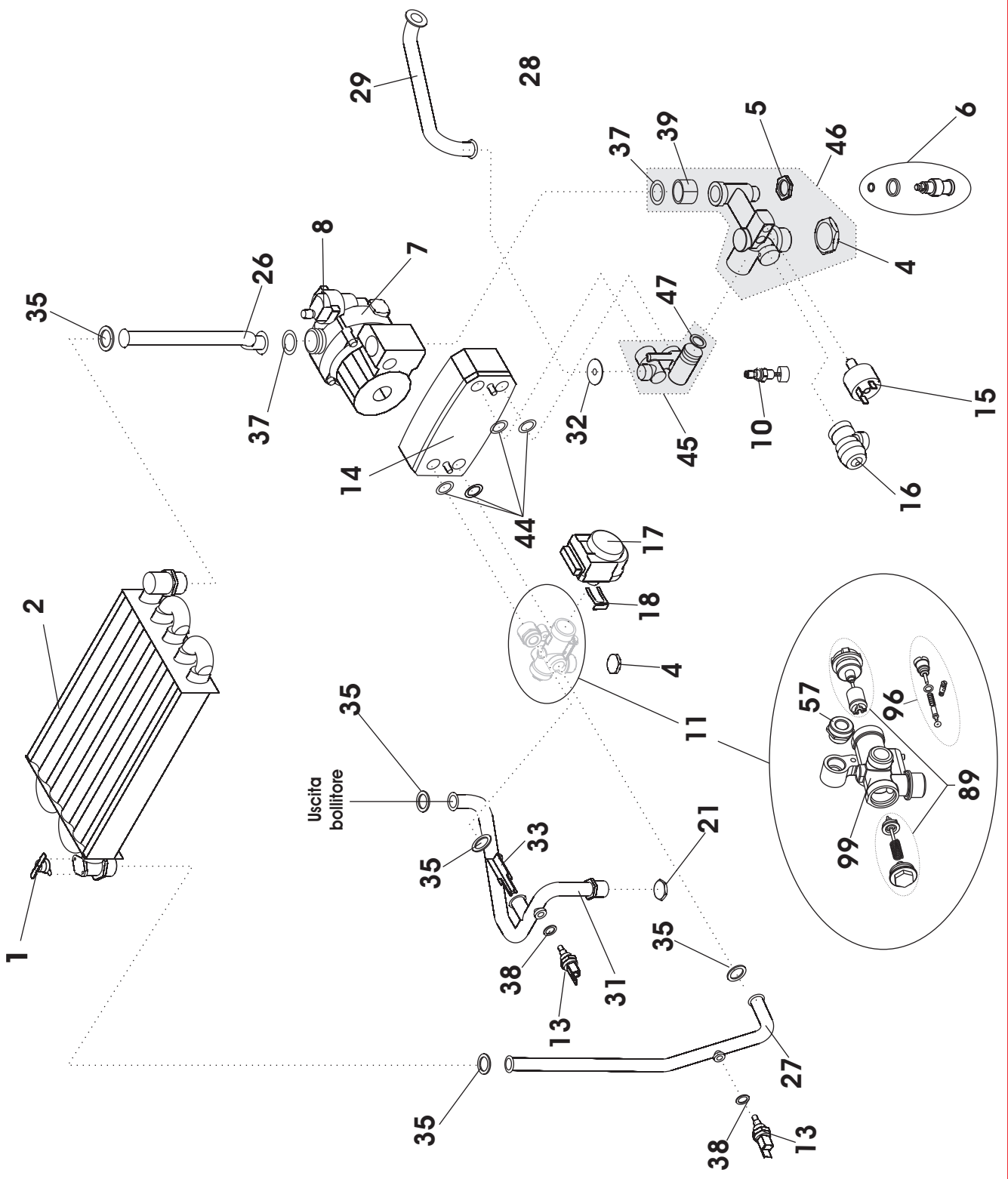

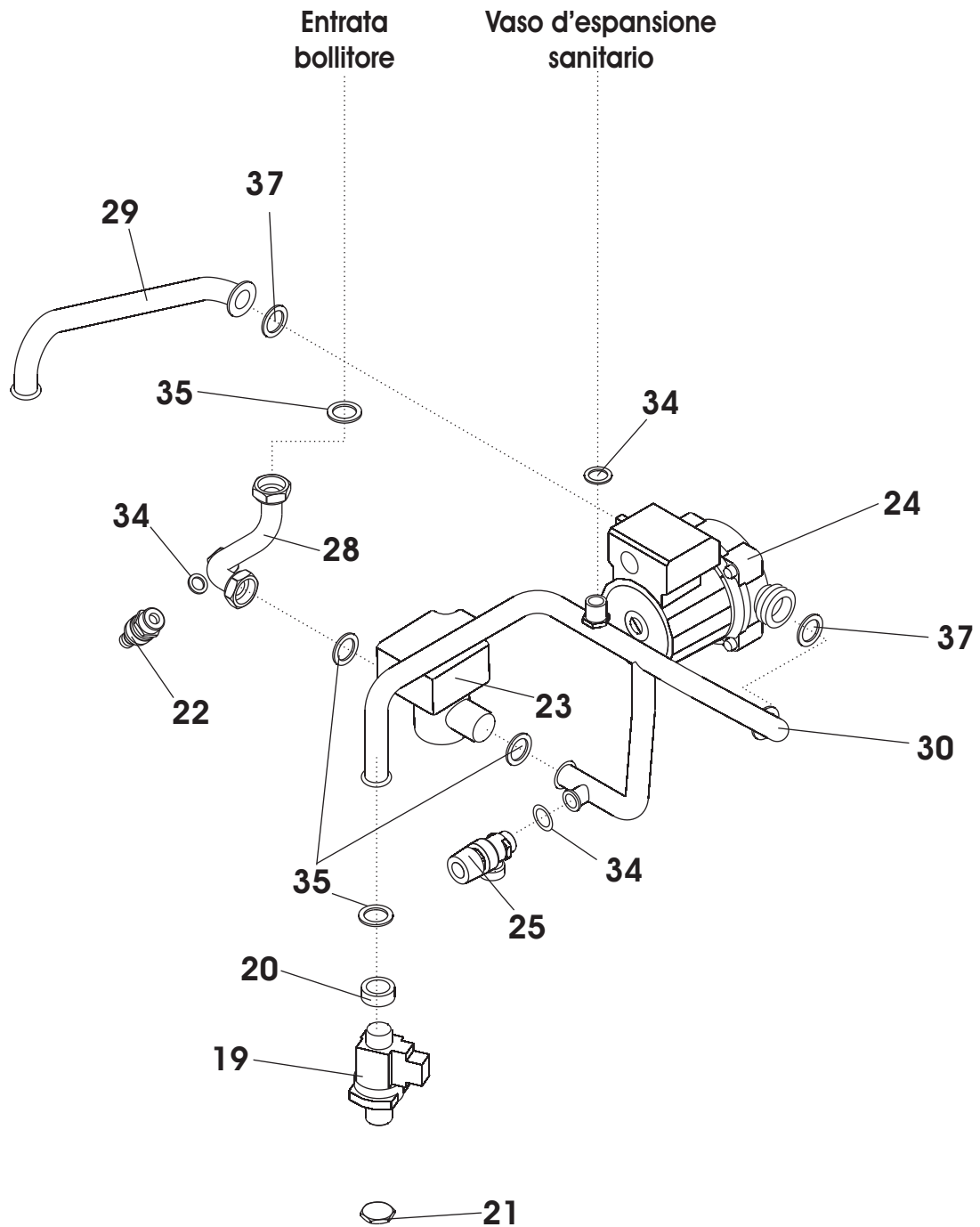

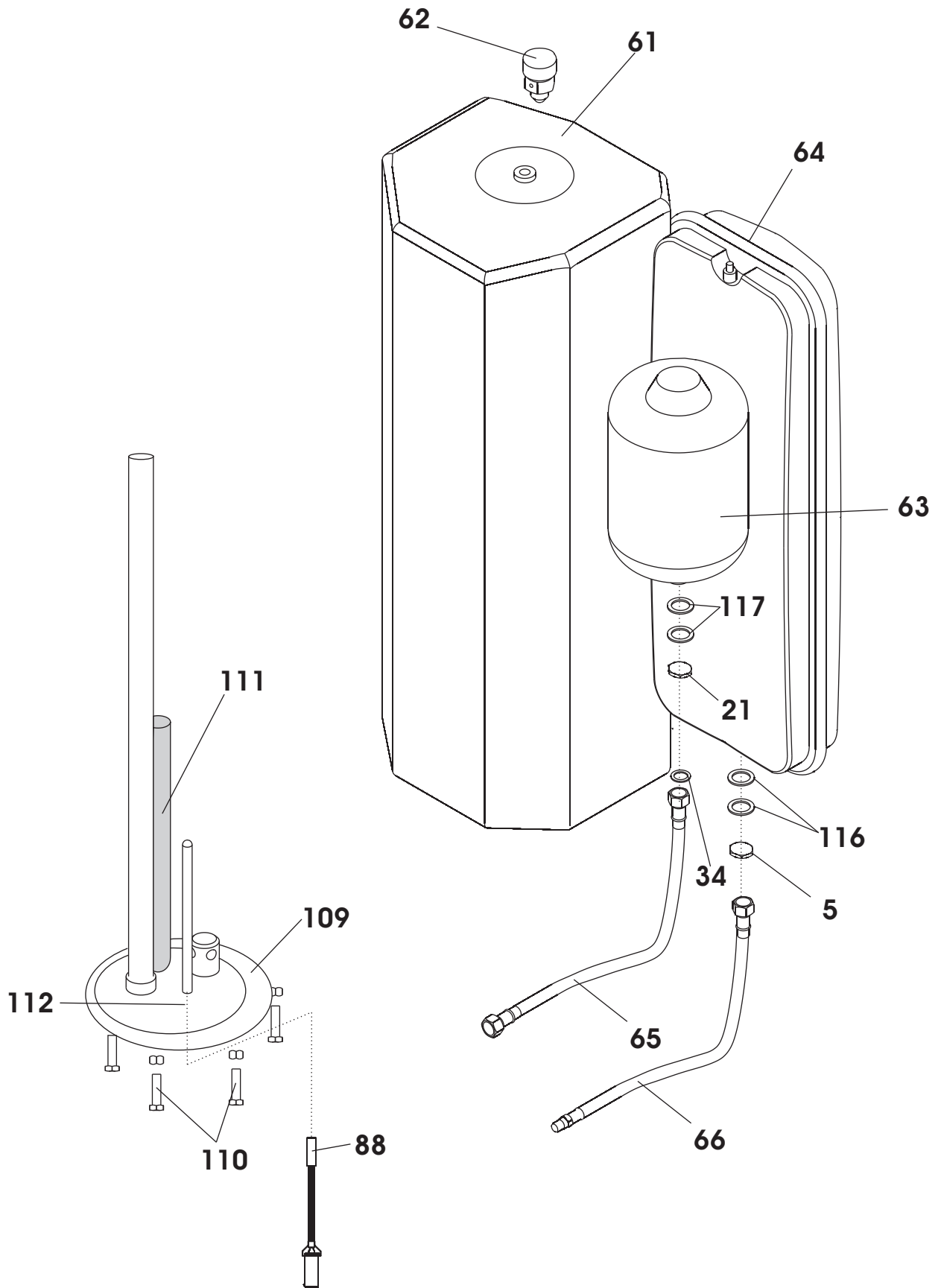

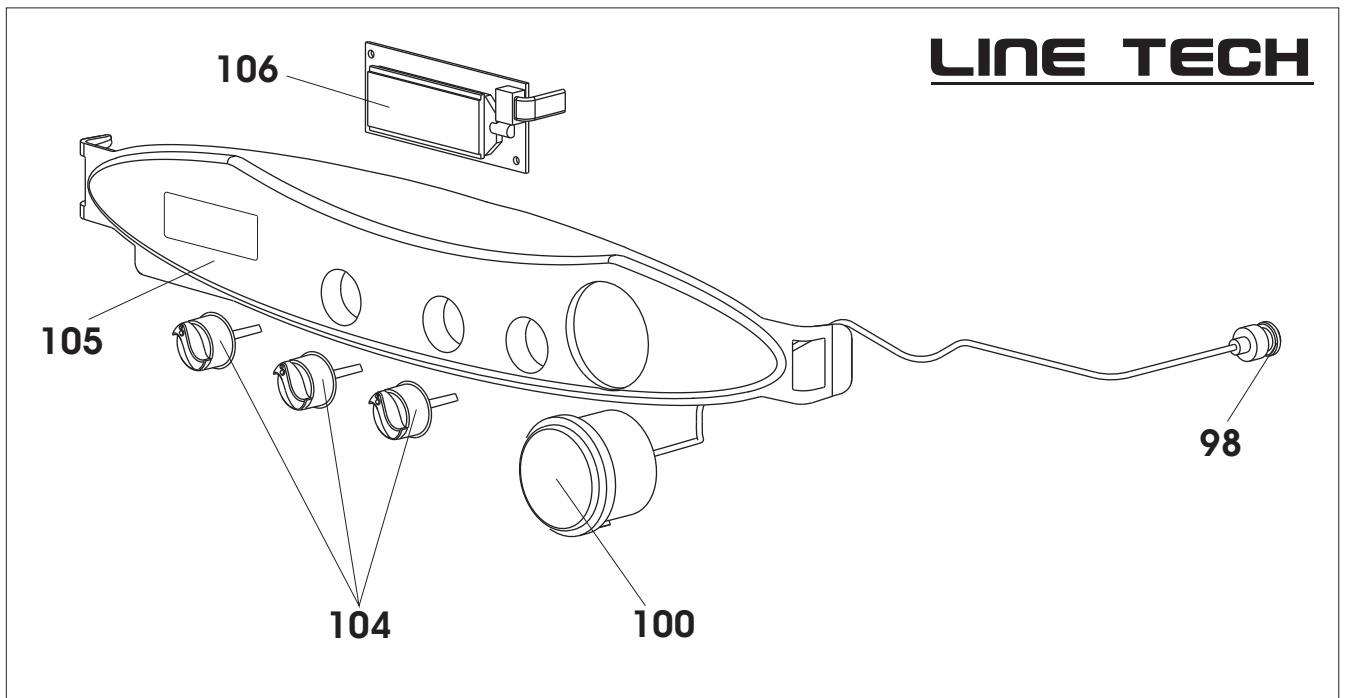
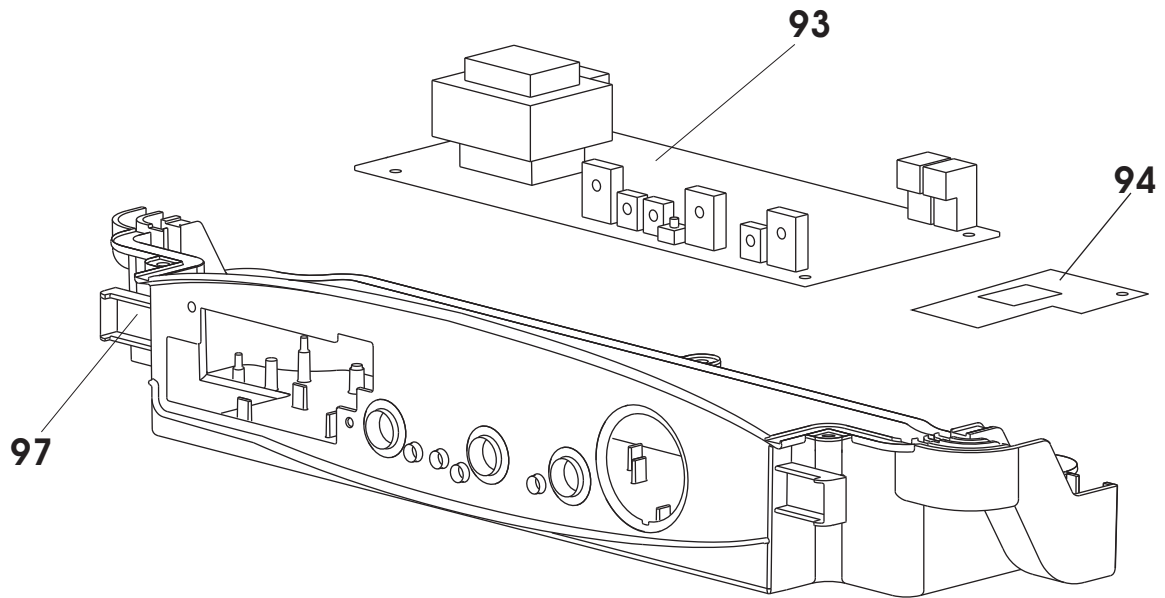

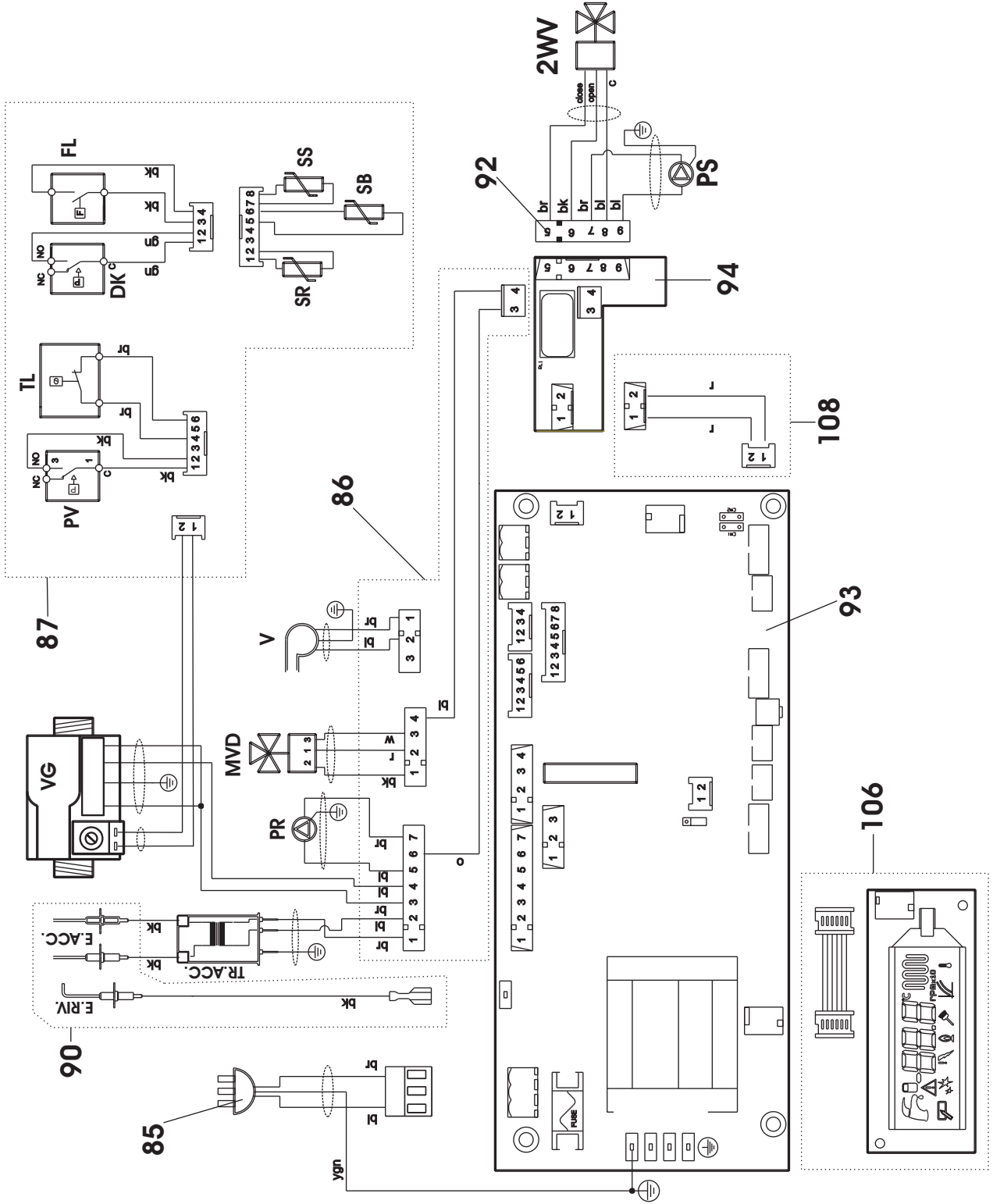

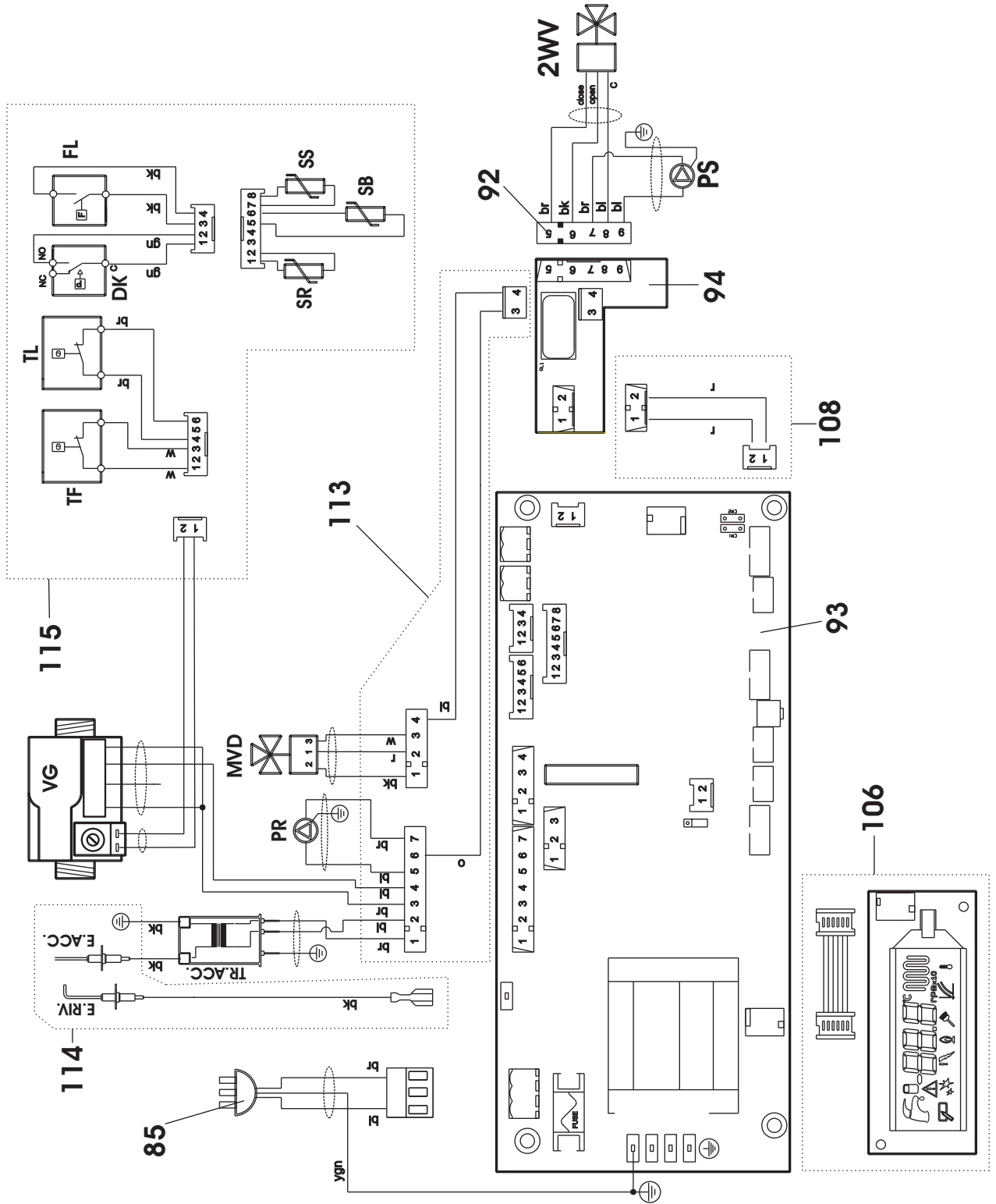

NIAS DUAL LINE TECH BTFS 24-28-32 BTN 24

Esp	Codice/Code	Pz/Pcs	Descrizione	Description
1	6YTERSI00	3	TERMOSTATO DI SICUREZZA 105 °C	SAFETY THERMOSTAT 105 °C
2	6SCAMMON05	1	SCAMBIATORE VALMEX MONOTERMICO 5 TUBI (24 KW)	VALMEX 5-DUCT EXCHANGER (24 KW)
	6SCAMPRI00	1	SCAMBIATORE PRIMARIO 5 TUBI OVALE (28-32 KW)	MAIN HEAT EXCHANGER - 5 OVAL PIPES (28-32 KW)
3	6DEFLINF00	1	DEFLETTORE INFERIORE CALDAIA 32KW	UNDER SIDE DEFLECTOR 32KW
4	6GHIEROT01	3	GHIERA ¾"	RING NUT G3/4"
5	6Y41138700	3	DADO DI FISSAGGIO PORTA-UGELLO PER BRUCIATORE	BURNER NOZZLE SECURING NUT
6	6RUBISCA01	1	CORPO RUBINETTO DI SCARICO PER CALDAIA	BOILER DRAIN COCK UNIT
7	6CIRCOLA07	1	CIRCOLATORE RSL 15/6-3-KU-CLR-3 (24-28 KW)	CIRCULATING PUMP RSL 15/6-3-KU-CLR-3 (24-28 KW)
	6CIRCOLA10	1	CIRCOLATORE RSL 15/7-3-KU-CLR-3 (32 KW)	CIRCULATING PUMP RSL 15/7-3-KU-CLR-3 (32 KW)
8	6DEGASAT00	1	DEGASATORE PER CALDAIE MURALI	DEGASSER FOR WALL-HUNG BOILERS
9	6SETISRC00	1	SET DI ISOLANTI RICAMBIO	COMPLETE SET OF INSULATING MATERIAL
10	6RUBICAR04	1	RUBINETTO DI RIEMPIMENTO KRAMER L=50	KRAMER L=50 FILLING TAP
11	6CORVAL03	1	CORPO VALVOLA A 3 VIE COMPLETO	3-WAY MOTORIZED VALVE BODY
12	6CAMCORC01	1	CAMERA DI COMBUSTIONE RICAMBIO TN	WALL-HUNG BOILERS TN COMBUSTION CHAMBER
13	6SONDNTC01	3	SONDA NTC AD IMMERSIONE DUAL LINE	NTC IMMERSION PROBE
14	6SCAMPIA05	1	SCAMBIATORE A 22 PIASTRE (24 KW)	22 PLATE HEAT EXCHANGER (24 KW)
	6SCAMPIA06	1	SCAMBIATORE A 26 PIASTRE (28-32 KW)	26 PLATE HEAT EXCHANGER (28-32 KW)
15	6PRESSAC00	1	PRESSOSTATO ACQUA	NO WATER PRESSURE SWITCH
16	6VALSIBA07	1	VALVOLA SICUREZZA 3 BAR INNESTO RAPIDO	3 BAR SNAP-ON SAFETY VALVE
17	6PROATTT00	1	PROGRAMMATORE ATTUATORE 1651/2.0.00	ACTUATOR PROGRAMMER 1651/2.0.00
18	6CLIFMEL00	3	CLIP FISSAGGIO MOTORE ELETTRICO	ELECTRIC MOTOR FIXING CLIP
19	6FLUSSOS00	1	FLUSSOSTATO BITRON	"BITRON" FLOW CONTROL
20	6RIDUZIO06	1	RIDUZIONE G1/2"F G3/4"M	ADAPTER G1/2"F G3/4"M
21	6GHIEROT00	3	GHIERA ½"	½" G RING NUT
22	6RUBISCA04	1	RUBINETTO DI SCARICO 1/2"	DRAIN COCK 1/2"
23	6VALVINT00	1	VALVOLA 2 VIE	2 WAY VALVE
24	6CIRCOLA09	1	CIRCOLATORE ZRS 15-2-1 KU	CIRCULATING PUMP ZRS 15-2-1 KU
25	6VALSIBA08	1	VALVOLA SICUREZZA 6BAR 1/2"	6 BAR SAFETY VALVE 1/2"
26	6TUBRIIM07	1	TUBO RITORNO IMPIANTO RISCALDAMENTO	RETURN DUCT FROM THE HEATING SYSTEM
27	6TUBMAIM11	1	TUBO DI MANDATA IMPIANTO RISCALDAMENTO	DELIVERY PIPE TO SYSTEM
28	6TUBACFR06	1	TUBO ACQUA FREDDA BOLLITORE	BOILER COLD WATER TUBE
29	6TUBACFR04	1	TUBO ACQUA FREDDA POMPA-SCAMBIATORE	CIRC. PUMP-HEAT EXCHANGER COLD WATER TUBE
30	6TUBACFR05	1	TUBO CARICO ACQUA FREDDA SANITARIA	WATER MAIN INLET PIPE
31	6TUBUSCS05	1	TUBO USCITA ACQUA CALDA SANITARIA	DHW FLOW PIPE
32	6DIAFRAM15	5	DIAFRAMMA CALDAIA MURALE 24KW 5.8MM	DIAPHRAGM 24KW 5.8MM
	6DIAFRAM16	5	DIAFRAMMA CALDAIA MURALE 28KW 6.0MM	DIAPHRAGM 28KW 6.0MM
	6DIAFRAM17	5	DIAFRAMMA CALDAIA MURALE 32KW 6.7MM	DIAPHRAGM 32KW 6.7MM
33	6TURBOLA01	1	TURBOLATORE ACQUA SANITARIA	COLD WATER SANITARIE FLUE TURBULENCE ENHANCER
34	6GROMNIA02	10	GUAR.1/2"OMNIA TESNIT BA-U18.5X11X2	GASKET 1/2" OMNIA TESNIT BA-U 18,5X11X2
35	6GROMNIA03	10	GUAR.3/4"OMNIA TESNIT BA-U 24X16X2	GASKET 3/4" OMNIA TESNIT BA-U 24X16X2
36	6TERMFUM01	1	TERMOSTATO FUMI 65°	THERMOSTAT 65°
37	6GROMNIA04	10	GUAR. 1" OMNIA TESNIT BA-U 30X21X2	GASKET 1" OMNIA TESNIT BA-U 30X21X2
38	6WRONDAL00	10	RONDELLA IN ALLUMINIO PER UGELLO	ALUMINIUM WASHER FOR NOZZLE
39	6GIRELLO03	3	GIRELLO G 1" PER RACCORDO POMPA	1" G PUMP FITTING COLLAR

40	6ISOLRIC00	1	ISOLAMENTO COMPLETO DI RICAMBIO DUAL LINE LINE 24 KW	COMPLETE INSULATION FOR MOD. DUAL LINE LINE 24
41	6FONDMUR11	1	FONDELLO PER CALDAIA CON ACCUMULO 07	BTN BASE
42	6LAMIAANT00	1	LAMIERA ANTI-IRRAGGIAMNETO PER CALDAIA MURALE	ANTI-RADIATION PLATE FOR WALL-HUNG BOILERS
43	6SCHPOST08	1	SCHIENALE POSTERIORE PER CALDAIA BTN	BTN REAR PANEL
44	6ORSCAPI00	10	O-RING DI TENUTA SU SCAMBIATORE A PIASTRE	PLATE HEAT EXCHANGER O-RING SEAL
45	6GRURIRC01	1	GRUPPO RACCORDO PER SCAMBIATORE	SPARE FILLING TAP UNIT
46	6GRIDRIR00	1	GRUPPO IDRAULICO RICAMBIO DI RITORNO RISC.	HYDRAULIC UNIT FOR HEATING RETURN CIRCUIT
47	6ORRASCPO0	10	O-RING DI TENUTA SU RACCORDO PER SCAMBIATORE	HEAT EXCHANGER O-RING SEAL
48	6DEFLPOS00	1	DEFLETTORE POS. PER CAPP A FUMI DUAL LINE 28	POSTERIOR DEFLECTOR FOR DUAL LINE 28
	6DEFLPOS01	1	DEFLETTORE POSTERIORE CALDAIA 32KW	POSTERIOR DEFLECTOR 32KW
49	6DEFLEDX00	1	DEFLETTORE DESTRO CAPP A FUMI CALDAIA 24-28 KW	RIGHT DEFL.FOR WALL-HUNG BOIL.FLUE GAS HOOD
	6DEFLEDX01	1	DEFLETTORE DESTRO PER CALDAIA 32KW	DX DEFLECTOR 32KW
50	6VENTILA07	1	VENTILATORE FIME 24KW	24 KW FAN
	6VENTILA10	1	VENTILATORE 28KW	28 KW FAN
	6VENTILA09	1	VENTILATORE 32KW	32 KW FAN
51	6DEFLESX00	1	DEFLETTORE SINISTRO CAPP A FUMI CALDAIA 24-28 KW	LEFT DEFL.FOR WALL-HUNG BOIL. FLUE GAS HOOD
	6DEFLESX01	1	DEFLETTORE SINISTRO CALDAIA 32KW	SX DEFLECTOR 32KW
52	6DEFLANT00	1	DEFLETTORE ANT. PER CAPP A FUMI DUAL LINE 28	FRONTAL DEFLECTOR FOR DUAL LINE 28
	6DEFLANT02	1	DEFLETTORE ANTERIORE CALDAIA 32KW	FRONT SIDE DEFLECTOR 32KW
53	6ALETTC A00	1	ALETTA LATERALE PER CAPP A FUMI	SIDE WING FOR FLUE GAS HOOD
54	6CAPFURC00	1	CAPP A FUMI RICAMBIO COMPATTA	FLUE GAS HOOD FOR WALL-HUNG BOILERS
55	6YPRESSO00	1	PRESSOSTATO ARIA 42/52 PA 24 KW	AIR PRESSURE SWITCH 42/52 PA 24 KW
	6PRESSOS02	1	PRESSOSTATO ARIA 67/57 PA 28-32 KW	AIR PRESSURE SWITCH 67/57 PA 28-32KW
56	6YSTATER00	1	STAFFA DI SUPPORTO TERM.SIC.	SUPPORTING BRACKET FOR SAFETY THERMOSTAT
57	6NIPCORP00	1	NIPPLE G3/4" PER G1/2"	G3/4" G1/2" NIPPLE
58	6SETISRC00	1	SET DI ISOLANTI RICAMBIO COMPATTE	COMP.SET OF INSULATING MAT.WALL-HUNG BOIL.
59	6CAMCORC00	1	CAMERA DI COMBUSTIONE RICAMBIO COMPATTA	COMBUSTION CHAMBER FOR WALL-HUNG BOILERS
60	6YTUBCON02	3m	TUBO IN SILICONE DIAMETRO INT. 4, ESTERNO 8	SILICONE PIPE: INSIDE Ø 4 MM, OUTSIDE Ø 8 MM
61	6BOLLITO09	1	BOLLITORE 25 LITRI	25 LITRES TANK
62	6VALVSFI02	5	VALVOLA SFOGO 1/2"	1/2" RELIEF VALVE
63	6VASOESP16	1	VASO D'ESPANSIONE 2 LT	2 LITRE EXPANSION VESSEL
64	6VASOESP17	1	VASO D'ESPANSIONE 8 LT 24KW	8 LITRE EXPANSION VESSEL 24 KW
	6VASOESP15	1	VASO D'ESPANSIONE 10 LT 28-32KW	10 LITRE EXPANSION VESSEL 28-32 KW
65	6TUBFLEX05	1	TUBO FLESSIBILE	HOSE PIPE
66	6TUBFLEX02	1	TUBO FLESSIBILE F 3/8"X M10X1 X 450	HOSE PIPE F 3/8"X M10X1 X 450
67	6STRUPOR00	1	STRUTTURA PORTANTE CALDAIA	BOILER SUPPORTING STRUCTURE
68	6PANFRCM06	1	PANNELLO FRONTALE LINE FN SENZA FORO VISORE	DUAL LINE LINE FN FRONT PANEL WITHOUT INSPECTION HOLE
69	6PANLACM01	1	PANNELLO LATERALE	SIDE PANEL
70	6FONDMUR04	1	FONDELLO	BASE
71	6PIASFIS01	1	PIASTRA FISSAGGIO BOLLITORE	VESSEL HEATER CLAMP
72	6FRONCAM00	1	PANNELLO FRONTALE DELLA CAMERA COMBUSTIONE	COMBUSTION CHAMBER FRONT PANEL
73	6POSTCAM00	1	PANNELLO POSTERIORE DELLA CAMERA COMBUSTIONE	COMBUSTION CHAMBER REAR PANEL
74	6STASOST04	1	STAFFA DI AGGANCIO PER SOSTEGNO A MURO	HOOKING WALL BRACKET
75	6PROFPOR00	2	PROFILO PORTANTE CALDAIA	BOILER SUPPORTING PROFILE
76	6CURFIVG00	1	CURVETTA DI FISSAGGIO X VALVOLA SIT	ELBOW FOR SIT GAS VALVE
77	6VALVGAS04	1	VALVOLA GAS SIT SIGMA 845	GAS VALVE SIT SIGMA 845
78	6TUBOGAS11	1	TUBO GAS	GAS TUBE

79	6CANDELA00	3	CANDELETTA D'ACCENSIONE	SPARK PLUG
	6BRUMMET03	1	BRUCIATORE 12 RAMPE METANO 24KW	COMPLETE BURNER, 12 RAMPS, METHANE 24 KW
	6BRUMMET04	1	BRUCIATORE 13 RAMPE METANO 28KW	COMPLETE BURNER, 13 RAMPS, METHANE 28 KW
	6BRUMMET05	1	BRUCIATORE 15 RAMPE METANO 32KW	COMPLETE BURNER, 15 RAMPS, METHANE 32 KW
	6BRUMMET10	1	BRUCIATORE 12 RAMPE METANO 24KW BTN	BTN COMPLETE BURNER, 12 RAMPS, METHANE 24 KW
	6BRUMGPL03	1	BRUCIATORE 12 RAMPE G.P.L. 24KW	COMPLETE BURNER, 12 RAMPS, PLG 24 KW
	6BRUMGPL04	1	BRUCIATORE 13 RAMPE G.P.L. 28KW	COMPLETE BURNER, 13 RAMPS, PLG 28 KW
80	6BRUMGPL05	1	BRUCIATORE 15 RAMPE G.P.L. 32KW	COMPLETE BURNER, 15 RAMPS, PLG 32 KW
	0TRASGPL03	12	TRASFORMAZIONE A G.P.L. DUAL LINE 24	PLG CONVERSION KIT FOR 24 DUAL LINE
	0TRASGPL06	13	TRASFORMAZIONE A G.P.L. DUAL LINE 28	PLG CONVERSION KIT FOR 28 DUAL LINE
	0TRASGPL07	15	TRASFORMAZIONE A G.P.L. DUAL LINE 32	PLG CONVERSION KIT FOR 32 DUAL LINE
	0TRASMET04	12	TRASFORMAZIONE A METANO DUAL LINE 24	METHANE CONVERSION KIT FOR 24 DUAL LINE
	0TRASMET05	13	TRASFORMAZIONE A METANO DUAL LINE 28	METHANE CONVERSION KIT FOR 28 DUAL LINE
	0TRASMET07	15	TRASFORMAZIONE A METANO DUAL LINE 32	METHANE CONVERSION KIT FOR 32 DUAL LINE
81	6STASUBR00	2	STAFFA DI SUPPORTO BRUCIATORE	BURNER BRACKET
82	6YTRAACC00	1	TRASFORMATORE DI ACCENSIONE	IGNITION TRANSFORMER
83	6GUAVAGA01	1	GUARNIZIONE PER VALVOLA GAS	GASKET FOR SIT GAS VALVE
85	6CAVOALI00	1	CAVO DI ALIMENTAZIONE	SUPPLY CABLE
86	6CABLMUR22	1	CABLAGGIO POMPA RISC., VENTILATORE, MVD. VALVOLA GAS	PUMP-GAS VALVE- FAN - MVD CONNECTION
87	6CABLMUR28	1	CABLAGGIO SONDE, PRESSOSTATI, FLUSSOSTATO E TL	PROBE-NO WATER PRES.SWITCH-SAFETY THERM. CONN
88	6SONDNTC02	1	SONDA NTC	NTC IMMERSION PROBE
89	6OTTUPIA00	1	OTTURATORE RISCALDAMENTO E PIATTELLO SANITARIO	CH SHUTTER AND DHW PLATE
90	6CABLMUR07	1	CABLAGGIO PER LA RILEVAZIONE E ACCENSIONE	IGNITION AND DETECTION ELECTRODE CONNECTION
	6DIAFSCA01	3	DIAFRAMMA SCARICO FUMI 42MM	FLUE GAS DISCHARGE DIAPHRAGM Ø 42
	6DIAFSCA02	3	DIAFRAMMA SCARICO FUMI 45MM	FLUE GAS DISCHARGE DIAPHRAGM Ø 45
	6DIAFSCA04	3	DIAFRAMMA SCARICO FUMI 40MM	FLUE GAS DISCHARGE DIAPHRAGM Ø 40
	6DIAFSCA05	3	DIAFRAMMA SCARICO FUMI 49MM	FLUE GAS DISCHARGE DIAPHRAGM Ø 49
	6DIAFSCA07	3	DIAFRAMMA SCARICO FUMI 47MM	FLUE GAS DISCHARGE DIAPHRAGM Ø 47
	6DIAFSCA08	3	DIAFRAMMA SCARICO FUMI 51MM	FLUE GAS DISCHARGE DIAPHRAGM Ø 51
	92	6CABLMUR24	1	CABLAGGIO POMPA SANITARIO E VALVOLA 2 VIE
93	6SCHEMOD17	1	SCHEDA MODULAZIONE LINE TECH	ELECTRONIC MODULATION BOARD LINE TECH
94	6CIRCSTA08	1	SCHEDA RELE' PER GESTIONE ACQUA PREMIUM	RELAY PCB FOR AQUA PREMIUM MANAGEMENT
95	6WVETISP00	5	GUARNIZIONE IN SILICONE CON VETRINO D49MM	SILICONE GASKET WITH GLASS D49MM
96	6BYPRIDU00	1	BY-PASS RICAMBIO DUAL LINE	SPARE BY-PASS PIPE FOR DUAL LINE
97	6SCAELPA00	1	SCATOLA PER ELETTRONICA PANNELLO PORTASTRUMENTI	CONTROL PANEL BOX FOR ELECTRONIC PARTS
98	6ORINMA00	10	O-RING DI TENUTA INNESTO MANOMETRO	PRESSURE GAUGE O-RING SEAL
99	6CORTREV02	1	CORPO VALVOLA TRE VIE G 3/4	G 3/4 3-WAY VALVE BODY
100	6MANOMET01	1	MANOMETRO	PRESSURE GAUGE
101	6DEFCAAP00	2	DEFLETTORE CAPP A FUMI MURALI TN	DEFLECTOR FOR NATURAL DRAFT HOOD
102	6DEFLLANT03	1	DEFLETTORE ANTERIORE CAPP A FUMI BTN	FRONT DEFLECTOR FOR NATURAL DRAFT HOOD BTN
103	6CAPFUMU01	1	CAPP A FUMI MURALE TN	NATURAL DRAFT HOOD
104	6MANOPOL00	3	MANOPOLA D.18 PER CALDAIA MURALE FN	KNOB D 18 FOR FN BOILER INSTRUMENT PANELS
105	6FRONPAN11	1	PANNELLO PORTASTRUMENTI DUAL LINE LINE TECH FN	DUAL LINE LINE TECH INSTRUMENT PANEL FN
106	6SCHELCD00	1	SCHEDA LCD	LCD BOARD
107	6YBOBINA00	1	BOBINA VALVOLA SIT 840-845-848	840-845-848 SIT GAS VALVE COIL
108	6CABLMUR25	1	CABLAGGIO COLLEGAMENTO SCHEDE	ELECTRONIC BOARD CONNECTION
109	6GUARBOL02	1	GUARNIZIONE 8 FORI D.186	GASKET

110	6DADOBOL00	8	DADO ESAGONALE + VITE BOLLITORE	NUT + SCREW
111	6ANODMGN01	1	ANODO DI MAGNESIO	SACRIFICAL ANOD (MAGNESIUM)
112	6BLOCFLA00	1	BLOCCO FLANGIA BOLLITORE	FLANGE ASSEMBLY
113	6CABLMUR30	1	CABLAGGIO POMPA RISC., VALVOLA GAS, MVD	CH PUMP, GAS VALVE, MVD CONNECTION
114	6CABLMUR12	1	CABLAGGIO PER LA RILEVAZIONE E ACCENSIONE	IGNITION AND DETECTION ELECTRODE CONNECTION
115	6CABLMUR29	1	CABLAGGIO SONDE, TERM.FUMI, FLUSSOSTATO E TL	PROBE-NO WATER PRES.SWITCH-SAFETY THERM. CONN
116	6GUARNIZ27	10	GUARNIZIONE 27X17X1,5	GASKET 27X17X1,5
117	6GUARNIZ25	10	GUARNIZIONE 33X21X1,5	GASKET 33X21X1,5

